

REVISIONS  
 RELEASED PER  
 ECR L00369

## DIESEL ENGINE FIRE PUMP CONTROLLER 12 VDC or 24VDC NEGATIVE GROUND

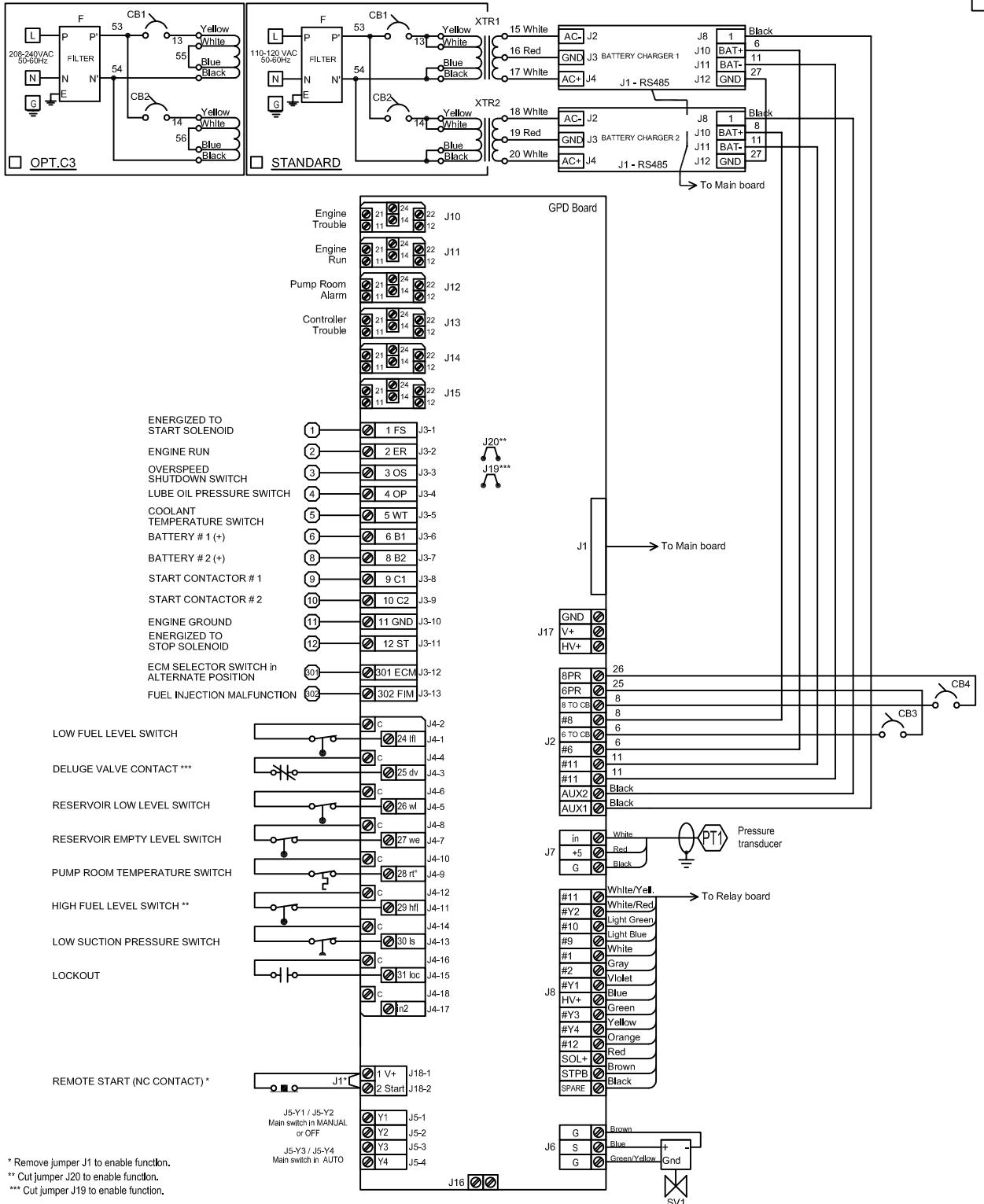

TITLE BUL. 10710 DIESEL ENGINE FIRE PUMP CONTROLLER  
 SCHEMATIC DIAGRAM  
 MADE BY L&T APP'D BY DJD  
 DATE 10/07/09

SCALE: 1/1  
 FILE: A10-10710-31  
 JOSLYN CLARK  
 ELIZABETHTOWN, NC USA 28337

A 10-10710-31

SHEET 1 OF 3 SHEET

DESIGN  
**B**

\* Remove jumper J1 to enable function.  
 \*\* Cut jumper J20 to enable function.  
 \*\*\* Cut jumper J19 to enable function.

Drawing for information only.  
 Manufacturer reserves the right to modify this drawing without notice.  
 For drawing for approval or installation, please contact manufacturer.

# DIESEL ENGINE FIRE PUMP CONTROLLER 12 VDC or 24VDC NEGATIVE GROUND

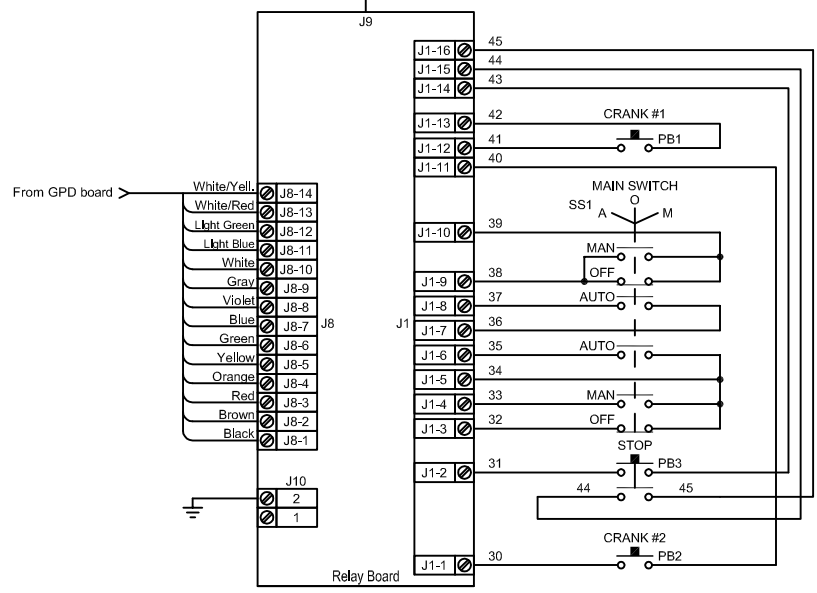
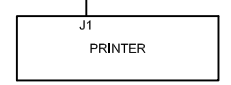
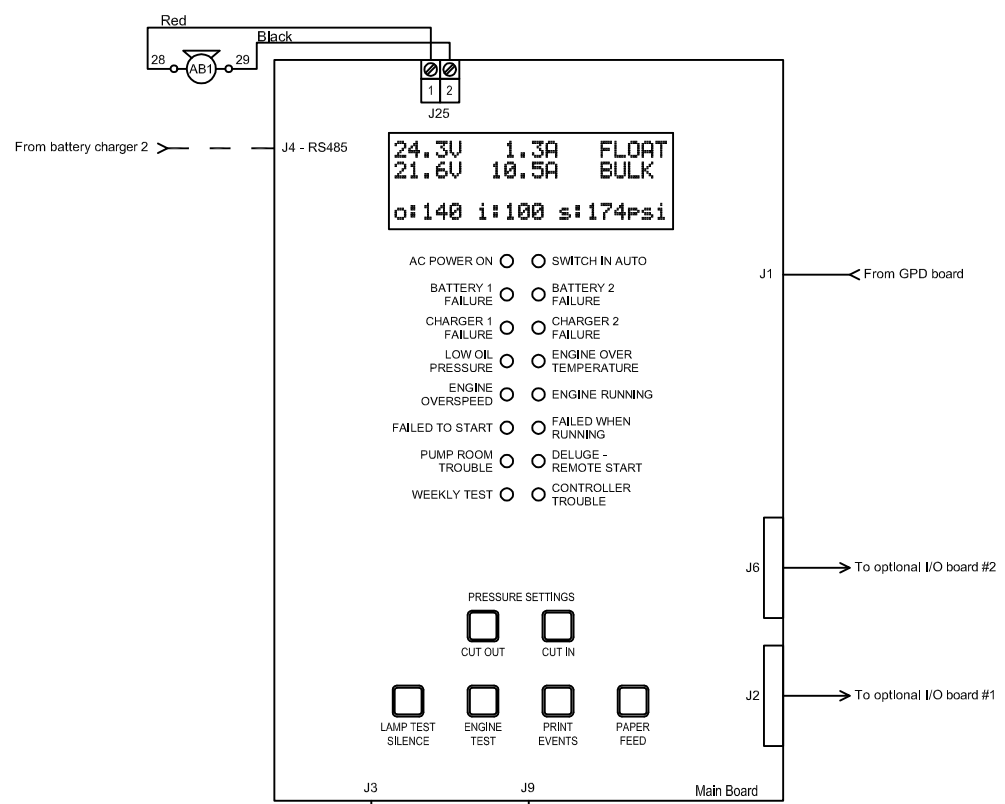

TITLE BUL. 10710 DIESEL ENGINE FIRE PUMP CONTROLLER  
 SCHEMATIC DIAGRAM  
 MADE BY L&T  
 DATE 10/07/09  
 APP'D BY DJD

SCALE: 1/1  
 FILE: A10-10710-31  
 JOSLYN CLARK CONTROLS, LLC.  
 ELIZABETH TOWN, NC USA 28387

A 10-10710-31  
 SHEET 2 OF 3 SHEET

DESIGN  
 B

# DIESEL ENGINE FIRE PUMP CONTROLLER 12 VDC or 24VDC NEGATIVE GROUND

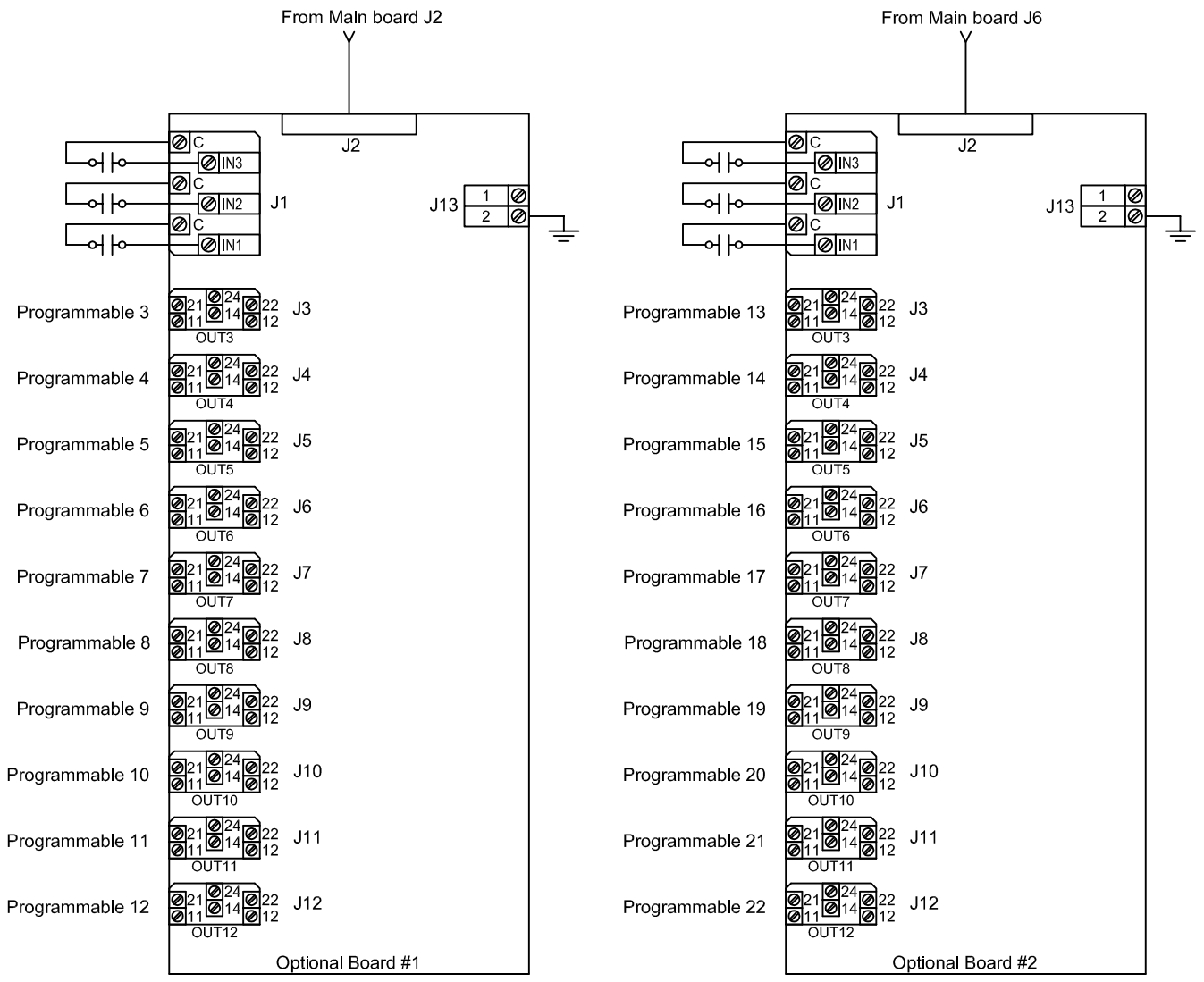

TITLE BUL. 10710 DIESEL ENGINE FIRE PUMP CONTROLLER

SCHEMATIC DIAGRAM

MADE BY L&T

DATE 10/07/09

APP'D BY DJD

*Joslyn Clark*

JOSLYN CLARK CONTROLS, LLC.  
ELIZABETHTOWN, NC USA 28337

SCALE: 1/1 FILE: A10-10710-31

**A**  
10-10710-31

SHEET 3 OF 3 SHEET

DESIGN  
**B**

REVISIONS
RELEASED PER ECR L00369
REV A: 09/01/10 REVISED PER ECR E00773, L&T

## DIESEL ENGINE FIRE PUMP CONTROLLER 12 VDC or 24VDC NEGATIVE GROUND

### POWER SUPPLY

TERMINALS WIRE SIZE:  
16 TO 6 AWG

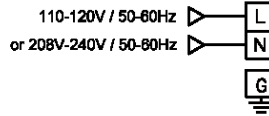

### ENGINE CONNECTION

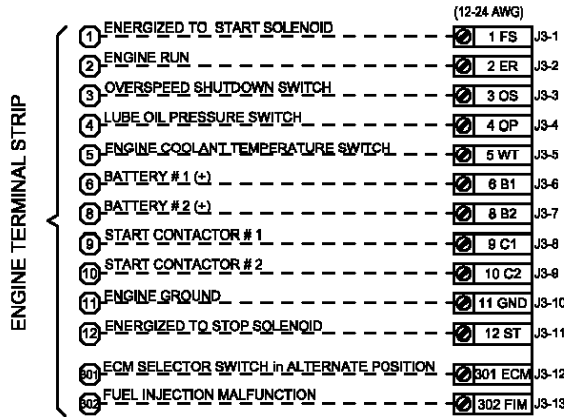

### ALARM CONTACTS

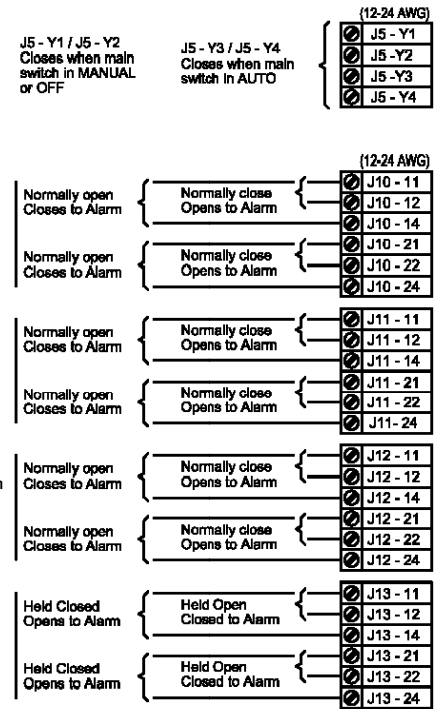

### FIELD CONNECTIONS

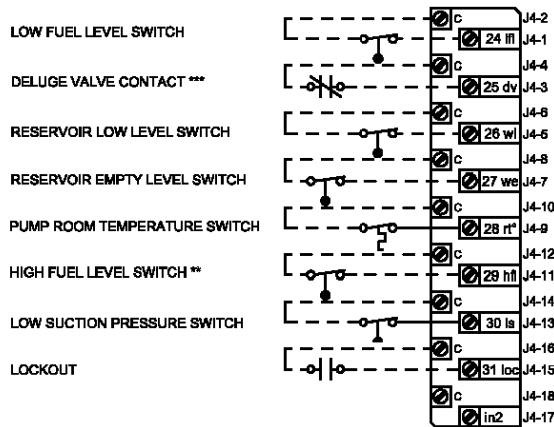

\* Remove jumper J1 to enable function.  
\*\* Cut jumper J20 to enable function.  
\*\*\* Cut jumper J19 to enable function.

REMOTE START (NC CONTACT) \*

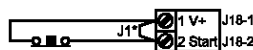

TITLE: BUL. 10710 DIESEL ENGINE FIRE PUMP CONTROLLER  
FIELD CONNECTIONS: \_\_\_\_\_  
MADE BY: L&T  
DATE: 10/07/09  
APP'D BY: DJD

Joseph Clark  
JOSLYN CLARK CONTROLS, LLC.  
ELIZABETH TOWN, NC USA 28937  
SCALE: 1/1  
FILE: A10-10710-32

**A 10-10710-32**  
SHEET 1 OF 1 SHEET

REV B  
DESIGN: 10710-32