

Description	Page Number
General Information - HP	C2
AC Magnetic Contactors - HP	C4
AC Magnetic Reversing Contactors - HP	C4
AC Magnetic Starters - HP	C5
AC Magnetic Reversing Starters - HP	C5
AC Magnetic Combination Starters - HP	C6
Modifications and Parts	C7
Modification and Spare Parts	C8
Numbering System	C9
Engineering Data	C10
For HP Overload Heaters see SectionB Index	

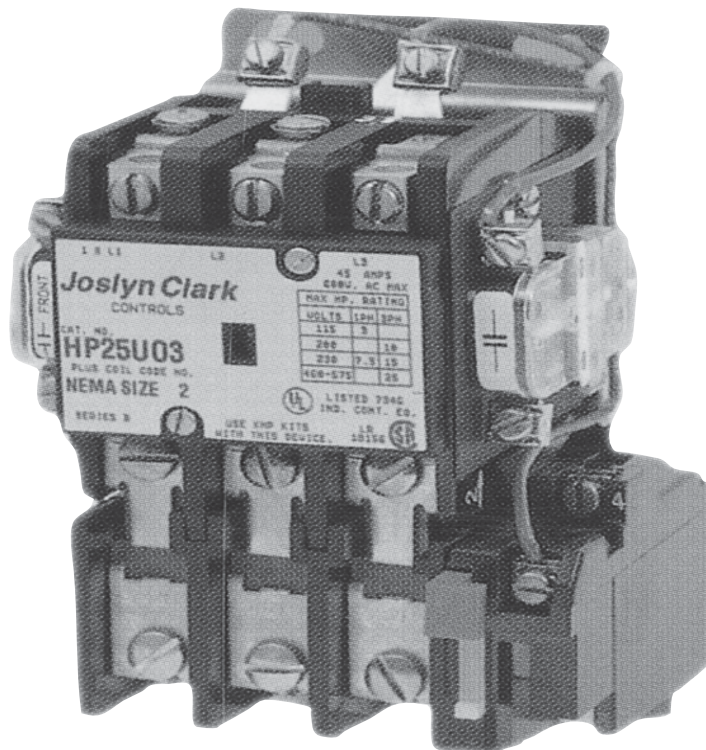

The Joslyn Clark NEMA Size Starter
That Saves You Money

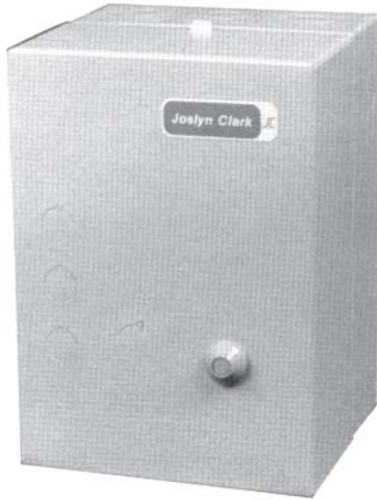

NEMA Type 1 Enclosed
Non - Reversing Starter

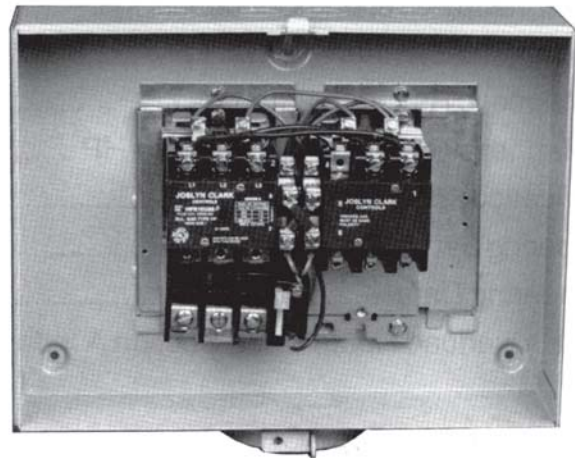

NEMA Type 1 Enclosed
Reversing Starter

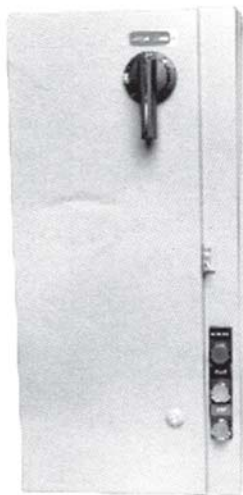

NEMA Type 1 Enclosed

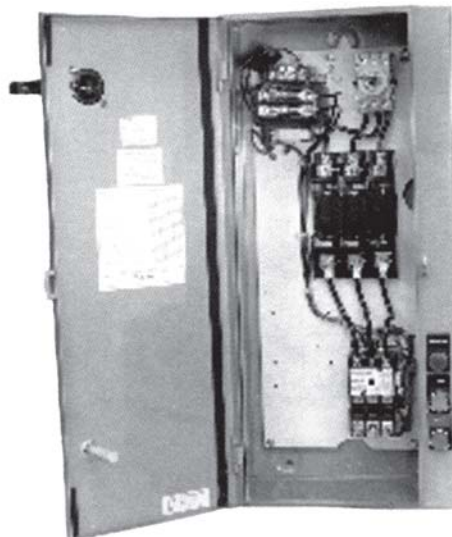

Combination Starters



Duplex Pump Controller

Quality — with economy of cost and space

The Joslyn Clark HP Motor Starter has been developed through many generations of controllers. Closely related to the TM design, the HP starter is rated for its horsepower capability as well as in standard NEMA frame sizes. Like the TM starter, our HP starter was designed in one piece as a starter, a single integrated unit consisting of a power contactor and a thermal overload relay mounted on a rigid common base.

This compact starter takes less than 19 sq. in. of panel space, permitting the use of smaller, less costly enclosures. It provides more wiring space for easy wiring and requires only two mounting screws to save installation time and cost

NEMA sizes 00, 0, 1 & 2 are the same small physical size, providing greater flexibility.



NEMA Sizes 00, 0, 1, & 2

Quality — with economy of cost and space

LOW ENERGY 8.4 VA COIL

Same energy efficient coil for NEMA sizes 00, 0, 1 & 2. Reduces transformer size and cost. Small transformer size saves panel space. Low VA inrush coil reduces line disturbance. ideal for use with solid state control.

TRUE "UP-FRONT" "STRAIGHT THROUGH" WIRING DESIGN

Makes the HP Starter easy to wire and safe to trace. Save through reduced wiring time and panel cost.

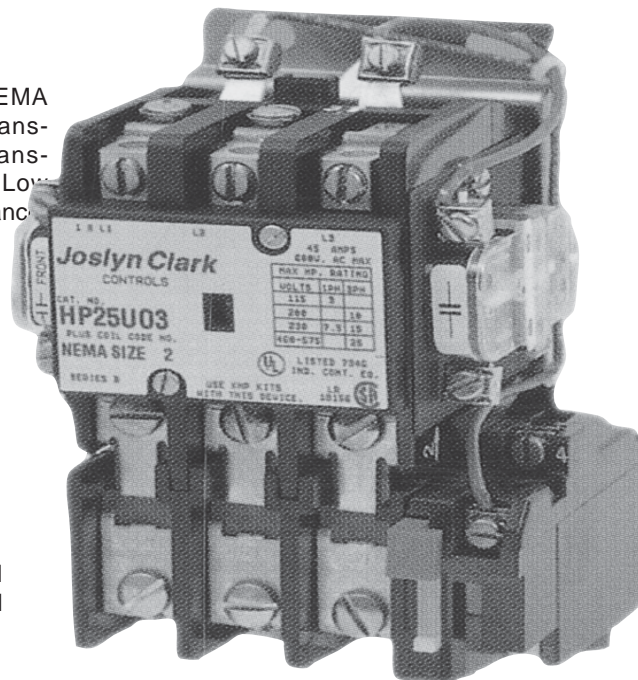

COVER NAME PLATE

Clear and easy to identify size, rating, and catalog number.

AUXILIARY CONTACTS

- Easy to install
- Clear side cover
- One Kit may be attached to each side of the starter providing up to four contacts
- Contacts positive driven from main contact carrier
- Contact Kits -
 - One N.O. **KHP - M10**
 - Two N.O. **KHP - M20**
 - N.O. & N.C. **KHP - M11**

SMALL SIZE

Requires only 19 sq. in. of panel space.

"UNIQUE" SPRING LOAD TERMINALS

For fast load connection. Save by reducing starter wiring time.

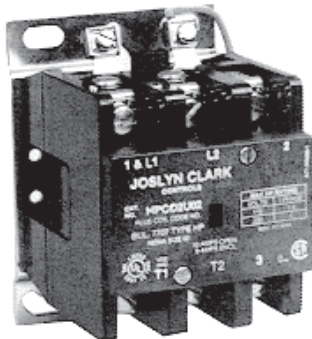

HPC020U2

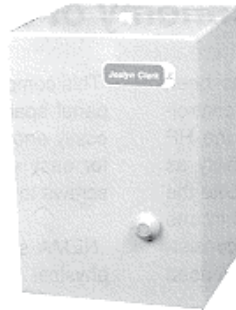

HPC10AA3

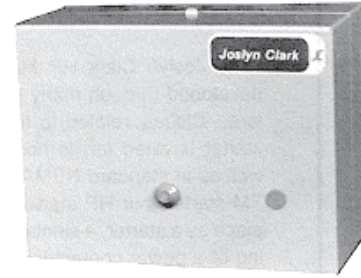

HPRC25A03

Non-Reversing Contactors - Type HPC

2-Pole, Single Phase

NEMA Size	Maximum Motor Horsepower Rating			Continuous Ampere Rating	Tungs Lamp Load	NEMA Type 1 General Purpose		NEMA Type 4 Watertight		NEMA Type 12 Industrial - Dust-tight		Open Type	
	115V	220V				Catalog No.	Price ¹	Catalog No.	Price ¹	Catalog No.	Price ¹	Catalog No.	Price ¹
00	1/3	1	----	9	5	HPC02A02 *	\$204.	HPC02W02 *	\$556.	HPC02T02 *	\$334.	HPC02U02 *	\$180.
0	1	2	----	18	10	HPC05A02 *	256.	HPC05W02 *	606.	HPC05T02 *	384.	HPC05U02 *	232.
1	2	3	----	27	15	HPC10A02 *	306.	HPC10W02 *	664.	HPC10T02 *	432.	HPC10U02 *	282.
2	3	7 1/2	----	45	30	HPC25A02 *	660.	HPC25W02 *	1260.	HPC25T02 *	810.	HPC25U02 *	510.

3-Pole, Three Phase

NEMA Size	Maximum Motor Horsepower Rating			Continuous Ampere Rating	Tungs Lamp Load	NEMA Type 1 General Purpose		NEMA Type 4 Watertight		NEMA Type 12 Industrial - Dust-tight		Open Type	
	200V	230V	460-575V			Catalog No.	Price ¹	Catalog No.	Price ¹	Catalog No.	Price ¹	Catalog No.	Price ¹
00	1 1/2	1 1/2	2	9	5	HPC02A03 *	234.	HPC02W03 *	586.	HPC02T03 *	364.	HPC02U03 *	210.
0	3	3	5	18	10	HPC05A03 *	286.	HPC05W03 *	636.	HPC05T03 *	414.	HPC05U03 *	262.
1	7 1/2	7 1/2	10	27	15	HPC10A03 *	336.	HPC10W03 *	690.	HPC10T03 *	462.	HPC10U03 *	312.
2	10	15	25	45	30	HPC25A03 *	660.	HPC25W03 *	1296.	HPC25T03 *	846.	HPC25U03 *	540.

Reversing Contactors - Type HPRC

3-Pole, Three Phase

NEMA Size	Maximum Motor Horsepower Rating			Continuous Ampere Rating	NEMA Type 1 General Purpose		NEMA Type 4 Watertight		NEMA Type 12 Industrial - Dust-tight		Open Type	
	200V	230V	460/575V		Catalog No.	Price ²	Catalog No.	Price ²	Catalog No.	Price ²	Catalog No.	Price ²
00	1 1/2	1 1/2	2	9	HPRC02A03 *	588.	HPRC02W03 *	1062.	HPRC02T03 *	800.	HPRC02U03 *	540.
0	3	3	5	18	HPRC05A03 *	696.	HPRC05W03 *	1170.	HPRC05T03 *	906.	HPRC05U03 *	648.
1	7 1/2	7 1/2	10	27	HPRC10A03 *	870.	HPRC10W03 *	1458.	HPRC10T03 *	1018.	HPRC10U03 *	800.
2	10	15	25	45	HPRC25A03 *	1572.	HPRC25W03 *	2484.	HPRC25T03 *	1818.	HPRC25U03 *	1380.

Note:

- Price includes contactor complete with one N.O. control-circuit contact.
- Price includes contactor complete with N.O. interlock on each contactor. All contactors are mechanically and electrically interlocked.

Ordering Information

- Use complete catalog number. Replace the (*) with the suffix from coil table.
- Engineering Data pages C10-13
- Modification pages C7-8

Coil Table

60Hz Voltage	Suffix	60Hz Voltage	Suffix
24 Separate Control	-96	200-240	-26
120 Separate Control	-76	277	-66
		440-480	-46
		550-600	-56

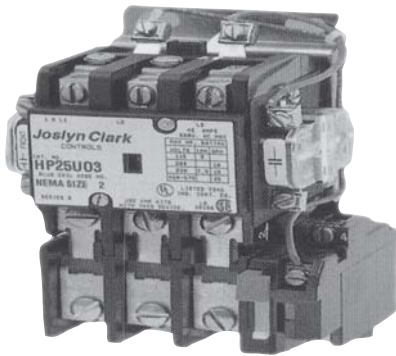

HP10U03

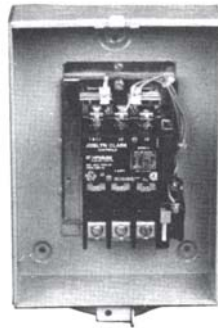

HP02AA3

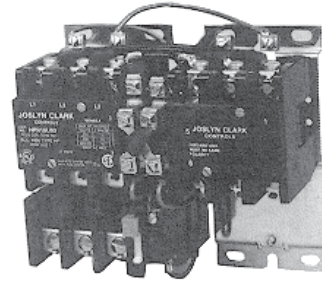

HPR10U03

Non-Reversing Starter Type HP

2-Pole, Single Phase (Requires 1 Overload Heater)												
NEMA Size	Maximum Motor Horsepower Rating			Contin-uous Ampere Rating	NEMA Type 1 General Purpose		NEMA Type 4 Watertight		NEMA Type 12 Industrial - Dust-tight		Open Type	
	115V	220V	460/575V		Price ¹	Catalog No.	Price ¹	Catalog No.	Price ¹	Catalog No.	Price ¹	
00	1/3	1	----	9	HP02AA2 *	\$ 286.	HP02WA2 *	\$ 618.	HP02TA2 *	\$ 396.	HP02U02 *	\$ 262.
0	1	2	----	18	HP05AA2 *	318.	HP05WA2 *	650.	HP05TA2 *	426.	HP05U02 *	294.
1	2	3	----	27	HP10AA2 *	366.	HP10WA2 *	708.	HP10TA2 *	474.	HP10U02 *	342.

3-Pole, Three Phase (Requires 3 Overload Heaters)												
NEMA Size	Maximum Motor Horsepower Rating			Contin-uous Ampere Rating	NEMA Type 1 General Purpose		NEMA Type 4 Watertight		NEMA Type 12 Industrial - Dust-tight		Open Type	
	200V	230V	460/575V		Price ²	Catalog No.	Price ²	Catalog No.	Price ²	Catalog No.	Price ²	
00	1 1/2	1 1/2	2	9	HP02AA3 *	286.	HP02WA3 *	618.	HP02TA3 *	396.	HP02U03 *	262.
0	3	3	5	18	HP05AA3 *	352.	HP05WA3 *	684.	HP05TA3 *	462.	HP05U03 *	328.
1	7 1/2	7 1/2	10	27	HP10AA3 *	400.	HP10WA3 *	742.	HP10TA3 *	510.	HP10U03 *	376.
2	10	15	25	45	HP25AA3 *	762.	HP25WA3 *	1380.	HP25TA3 *	928.	HP25U03 *	642.

Reversing Starters - Type HPR

3-Pole, Three Phase (Requires 3 Overload Heaters)												
NEMA Size	Maximum Motor Horsepower Rating			Contin-uous Ampere Rating	NEMA Type 1 General Purpose		NEMA Type 4 Watertight		NEMA Type 12 Industrial - Dust-tight		Open Type	
	200V	230V	460/575V		Price ²	Catalog No.	Price ²	Catalog No.	Price ²	Catalog No.	Price ²	
00	1 1/2	1 1/2	2	9	HPR02AA3 *	\$ 672.	HPR02WA3 *	\$ 1104.	HPR02TA3 *	\$ 838.	HPR02U03 *	\$ 624.
0	3	3	5	18	HPR05AA3 *	786.	HPR05WA3 *	1218.	HPR05TA3 *	952.	HPR05U03 *	738.
1	7 1/2	7 1/2	10	27	HPR10AA3 *	906.	HPR10WA3 *	1506.	HPR10TA3 *	1066.	HPR10U03 *	834.
2	10	15	25	45	HPR25AA3 *	1674.	HPR25WA3 *	2566.	HPR25TA3 *	1900.	HPR25U03 *	1482.

Note:

- Price includes starter complete with N.O. interlock and overload relay less heaters.
- Price includes starter complete with N.O. interlock on each contactor and overload relay less heaters. All starters are mechanically and electrically interlocked.
- NEMA 3R add 60.00 to NEMA 12 List

0
2
3

Ordering Information

- Use complete catalog number. Replace the (*) with the suffix from Coil Table.
- Order heater elements at \$18 each from Section B

- Engineering Data page C10-13
- Modification page C7-8
- Spare Parts C8

Coil Table

60Hz Voltage	Suffix	60Hz Voltage	Suffix
24 Separate Control	-96	200-240	-26
120 Separate Control	-76	277	-66
		440-480	-46
		550-600	-56

HP - NEMA Control

AC Combination Starters



HPS25AA3296

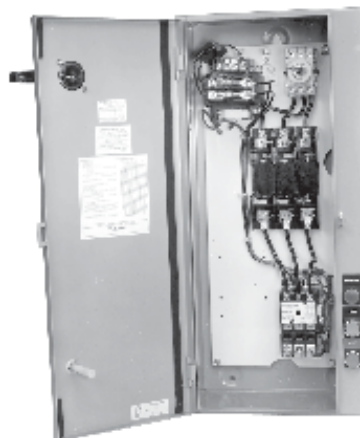

HPS25AA3296

Non-Fusible Disconnect Switch - Type HPS

NEMA Size	Maximum Motor Horsepower Rating ¹			Starter Ampere Rating	Disconnect Ampere Rating		NEMA Type 1 ³ General Purpose Enclosure		NEMA Type 3R ³ Raintight	
	200V	230V	460/575V		Switch	Fuse Clips	Catalog No.	Price ²	Catalog No.	Price
00	1 1/2	1 1/2	2	9	30	30	HPS02AA3610 *	\$ 786.	HPS02RA3610 *	\$ 1018.
0	3	3	5	18	30	30	HPS05AA3610 *	874.	HPS05RA3610 *	1104.
1	7 1/2	7 1/2	10	27	30	30	HPS10AA3610 *	922.	HPS10RA3610 *	1152.
2	10	10	25	45	60	60	HPS25AA3610 *	1378.	HPS25RA3610 *	1678.

Fusible Disconnect (200 & 230 Volts)

NEMA Size	Max. Motor Horsepower Rating ¹				Starter Ampere Rating	Disconnect Ampere Rating		NEMA Type 1 ³ General Purpose Enclosure		NEMA Type 3R ³ Raintight	
	Dual Element Fuse		Non-Time Delay Fuses			Switch	Fuse Clips	Catalog No.	Price ²	Catalog No.	Price
	200V	230V	200V	230V							
00	1 1/2	1 1/2	1 1/2	1 1/2	9	30	30	HPS02AA3293 *	\$ 814.	HPS02RA3293 *	\$ 1044.
0	3	3	3	3	18	30	30	HPS05AA3293 *	904.	HPS05RA3293 *	1134.
1	5	7 1/2	3	3	27	30	30	HPS10AA3293 *	952.	HPS10RA3293 *	1182.
1	7 1/2	----	7 1/2	7 1/2	27	30	60	HPS10AA3296 *	970.	HPS10RA3296 *	1200.
2	10	15	----	----	45	60	60	HPS25AA3296 *	1404.	HPS25RA3296 *	1714.

Fusible Disconnect (460 & 575 Volts)

NEMA Size	460V		575V		Starter Ampere Rating	Disconnect Ampere Rating		NEMA Type 1 General Purpose Enclosure		NEMA Type 3R Raintight	
	460V	575V	460V	575V		Switch	Fuse Clips	Catalog No.	Price ²	Catalog No.	Price
00	2	2	2	2	9	30	30	HPS02AA3693 *	\$ 828.	HPS02RA3693 *	\$ 1060.
0	5	5	5	5	18	30	30	HPS05AA3693 *	922.	HPS05RA3693 *	1152.
1	10	10	7 1/2	7 1/2	27	30	30	HPS10AA3693 *	970.	HPS10RA3693 *	1200.
1	----	----	10	10	27	30	60	HPS10AA3696 *	990.	HPS10RA3696 *	1222.
2	15	15	----	----	45	60	30	HPS25AA3693 *	1414.	HPS25RA3693 *	1722.
2	25	25	15	15	45	60	60	HPS25AA3696 *	1432.	HPS25RA3696 *	1740.

Notes:

- Motor Full load must not exceed starter continuous ampere rating.
- Prices includes starter complete with N.O. interlock, disconnect switch less fuses, and 3-phase overload relay less heaters.
- For other Enclosure Types consult factory.

2
0
6

Ordering Information

- Use complete catalog number. Replace the (*) with the suffix from coil table.
- Order heater elements at \$18 each from Section page B32
- Engineering Data pages C10-14
- Modification pages C7-8

Coil Table

60hz Voltage	Suffix	60Hz Voltage	Suffix
24 Separate Control	-96	200-240	-26
120 Separate Control	-76	277	-66
		440-480	-46
		550-600	-56

Modifications

Description	Factory Installation Price Addition - Change Catalog No. as outlined on Page C9.				For Field Installation Kit Catalog Number	Price		
	For Bulletin Number	Type HP Size	Enclosure Type					
			1	4 & 12	Kits Only For Type 1 Enclosures			
Cover Controls								
Over Load Reset Hole plug for Internal Reset (10 per pack)	6013, 6030 & 6018	00,0,1 & 2	N/C	N/C	KTM-26	\$ 48.		
Reset Button (one reset per kit)	6013 & 6030 6018				KHP-EC2 A60-	18. 36.		
Push Buttons & Selector Switches Start-Stop Push Buttons	6013, 6030, 6031, & 7707				\$ 96.	\$ 264.	KHP-4	60.
Hand-Off Auto Selector Switch ¹					96.	264.	KHP-8	60.
Forward-Reverse-Stop Selector Switch					96.	264.	KHP-8	60.
Forward-Reverse-Stop Push Button		480.	480.	KTM-18	300.			
Pilot Lights Without Electrical Interlocks, Standard Transformer Type, with Red Lens.	120V 6013, 240V 6030, 480V 6031, 600V & 7707	90.	90.	KTM5-4	66.			
		90.	90.	KTM5-5	66.			
		90.	90.	KTM5-6	66.			
		90.	90.	KTM5-7	66.			
Push Buttons & Selector Switches Start-Stop Buttons	6018	00,0,1 & 2	96.	---	KTM5-1	60.		
Hand-Off-Auto Selector Switch					KTM5-3	60.		
Pilot Lights Without Electrical Interlocks, Standard Transformer Type, with Red Lens.			120V 240V 480V	180.	---	KTM5-4 KTM5-5 KTM5-6	132. 132. 132.	
Control Circuit								
Auxillary Contacts Extra N.O. Contact Extra N.O. and N.C. Contacts Two extra N.O. Contacts	All	All	132. 198. 198.	132. 198. 198.	KHP-M10 KHP-M11 KHP-M20	60. 90. 90.		
Enclosure Kits	6013 & 6030				Same as type TM, see Section B			

C

Power Circuit - For HPS Combination Starters

Fuse Clips-Kit includes 6 clips and mounting screws, without base for lower clips. ²						
Description	Fuse Class	Switch Amp. Size	For Bulletin Number	Type HP Size	Catalog No.	Price
Base 30 Amp. 250 Volts	R	30 & 60	6018	00-2	A63-452135-2	\$48.
60 Amp. 250 Volts	R				A63-452133-2	48.
30 Amp. 600 Volts	R				A63-452136-2	72.
60 Amp. 600 Volts	R				A63-452841-2	72.

Note:

1. Kits may be changed in the field from 3-position to 2-position operation. In addition to HAND-OFF-AUTO, four labels are included, marked FORWARD-OFF-REVERSE: HIGH-OFF-LOW, TEST-LAG-LEAD, ON-OFF.

2. Lower Mounting Base for Fuse Clips- required only when converting a non-fusable unit to a fusable unit.

1
8
6

Modifications

Description	Factory Installed Price Addition			For Field Installation Kit Catalog Number	Discount Schedule JC12 Price			
	For Bulletin Number	Type HP Size	Add to NEMA Type 1, 4 & 12					
Control Transformer - Includes Single Fused 120 Volt Secondary								
	V A Capacity	Primary Voltage	Hertz					
Standard ³ Capacity	50	208 240 & 480 600	50/60	6013 & 6018	00-2	2		
Extra ³ Capacity	150	208 240 & 480 600				324.	KTR67-16 KTR67-2 KTR67-12	\$216.
						576.	KTR67-20 KTR67-5 KTR67-25	\$264.
Miscellaneous								
Ambient Compensated Overload Relay			All	00-2	24.			
Fused Control Circuit:								
Fuse Holder for one fuse			All	00-2	264.		KHP-F1	\$48.
Fuse Holder for two fuses							KHP-F2	72.
Enclosure Adaptor Kits:								
Starter Mounting Plate							KHP-EC1	\$24.
Mtg. Plate with O/L Reset - Required with Enclosure Kit							KHP-EC3	42.
Transformer Mtg. Plate ¹							KTM-28	24.

Renewal Parts	Size	Discount Schedule JC80	
Replacement Overload	00-2	KHP31-15	\$ 124.
Ambient Compensated	00-2	KHPA31-15	156.
Replacement Power Contact Kit	00-1	KHP31-1	166.
	2	KHP32-1	260.
	Forward Side	KHPR31-S	189.
	00-1 Reverser		
	Reverse Side	KHPR31-C	189.
	00-1 Reverser		
	Forward Side	KHPR32-S	283.
Size 2 Reverser			
Reverse Side	KHPR32-C	283.	
Size 2 Reverser			
Replacement Coil Kits		Discount Schedule JC80	
Voltage	Hertz		
110-120	50 or 60	00, 0, 1 & 2	KTB174-1
208-240	50 or 60		\$ 97.
440-480	50 or 60		KTB174-2
550-600	50 or 60		97.
380	50 or 60		KTB174-5
277	50 or 60		97.
24	50 or 60		KTB174-6
			97.
			KTB174-7
			97.
			KTB174-4
			97.
			KTB174-3
			97.

Notes:

1. Reversing Starters require 1-KHP-EC1 and 1-KHP-EC3 with reset.
2. Prices include larger cabinets required for Bul. 6013 & 6030.
3. Includes one secondary fuse and 2 Primary Fuse Clips.

Type of Contactor or Starter
HPC - Contactor
HP - Starter
HPRC - Reversing Contactor
HPR - Reversing Starter
HPS - Combination Starter with Switch

NEMA Size
02 - Size 00
05 - Size 0
10 - Size 1
25 - Size 2

Enclosure Type	
A - NEMA 1	
B - NEMA 2	
R - NEMA 3R	
P - NEMA 4- Painted Steel	
*W - NEMA 4-Stainless Steel	
*T - NEMA 12	
U - Open Type	
Type W & T enclosures are not available with HPS combination starters. Use type TM for these applications.	

Number of Poles
2 - Two Pole
3 - Three Pole

Fuse Clip Size	
Fuse Clip	Class R Fuse Clip
03 - 30 ampere	93 - 30 ampere
06 - 60 ampere	96 - 60 ampere
Class J Fuse Clip	No number or
13 - 30 ampere	10 - no clips
16 - 60 ampere	

Pilot Light
L - Indicates a standard red pilot light.
P - Indicates a "Push-To-Test" red transformer type pilot light with nameplates.
No Letter - Pilot light not required.

HPS 10 A A 3 6 03 - T46 L M10

Cover Control
Bulletins 6013, 6018 & 7707
A - Reset button in cover for overloads.
B - Reset button and Hand-Off-Auto selector switch.
C - Reset button and Start-Stop push button.
E - Selector switch no reset.
F - Push button no reset.
O - None (no reset button in cover)
Bulletins 6030 & 6031
A - Reset button in cover for overloads.
B - Reset button and Fwd.-Off-Rev. selector switch.
C - Reset button and Fwd.-Rev.-Stop push button.
O - None (no reset button in cover)

Indicates Type of Overload Relay
A - Ambient compensated
No Letter - Non Ambient compensated

Disconnect Rating
2 - 240 Volts
4 - 480 Volts
6 - 600 Volts
No number - No switch

Indicates Quantity of Auxiliary Contacts
M10 = 1 N.O. Contact
M20 = 2 N. O. Contacts
M11 = 1 N.O. 1 N.C. Contact

Suffix Without Transformer		
Coil Volts & Hertz	Suffix	
110-120/50 or 60	- 76	
220-240/50 or 60	- 26	
440-480/50 or 60	- 46	
550-600/50 or 60	- 56	
200-208/50 or 60	- 86	
277/50 or 60	- 66	
24/50 or 60	- 96	
Suffix With Transformer		
(Secondary 110-120V)		
Transformer Primary Volts & Hertz	Suffix	
	Standard Capacity	100 Watt Extra Capacity
220-240/50 or 60	- T26	- C26
440-480/50 or 60	- T46	- C46
550-600/50 or 60	- T56	- C56
200-208/50 or 60	- T86	- C86

Type HP NEMA Sizes 00, 0, 1 & 2 Outline Drawings

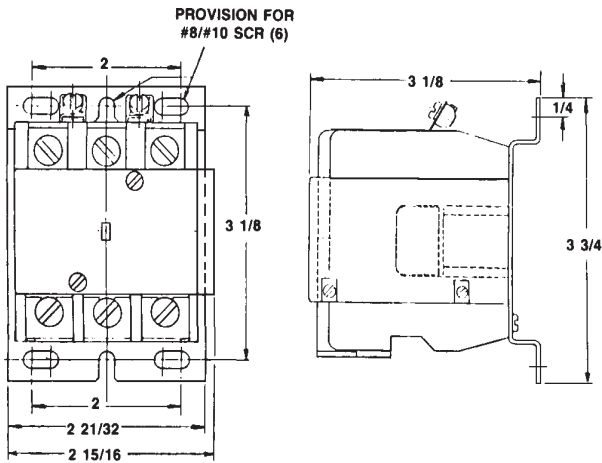

Contactor Type HPC

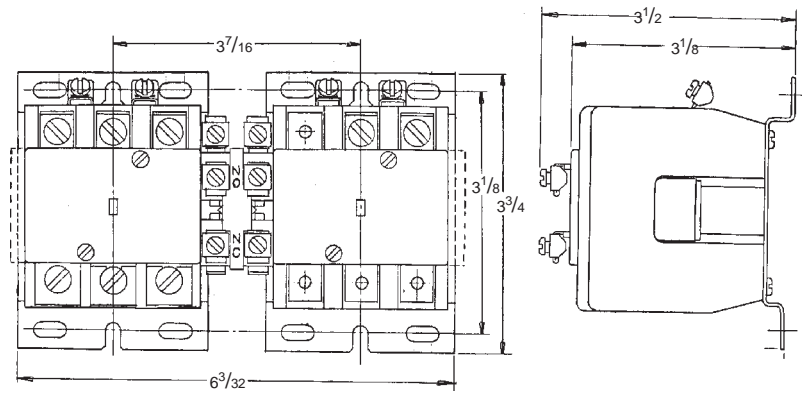

Reversing Contactor Type HPRC

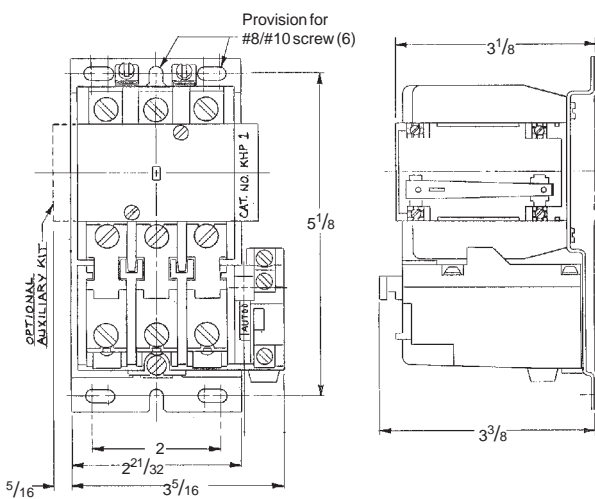

Starter Type HP

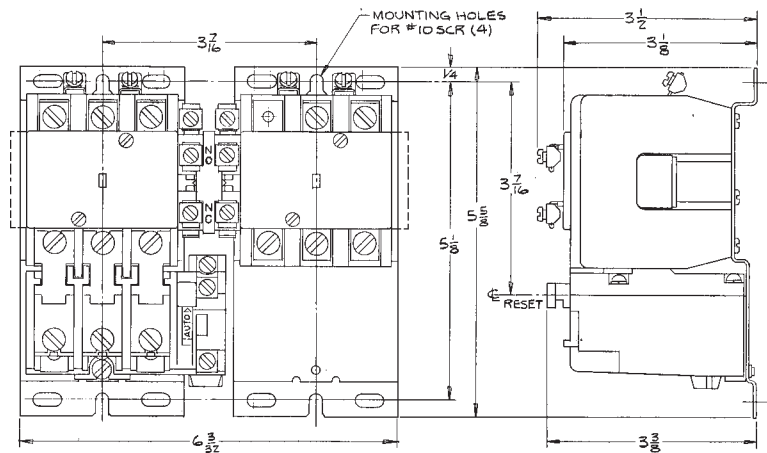

Reversing Starters Type HPR

Power Wiring Accommodations				Control Circuit									
Wire Range	Wire Type	Pressure Terminal Type	Provision for Ring Tongue Lugs ¹	Continuous Amperes	A-C Inductive		Terminal Type	Copper Wire Size Max. ^{2,3}	Screw Size	Coil Burden			
					Line	Load				Make	Break	Inrush	Sealed
# 14 - #8	#14 - #4	Copper (Cu)	Pressure Clamp	.450	5	880VA	40VA	Pressure Saddle	#12AWG	#6 - 32	48VA	8.4VA	

Notes:

1. UL specifies only one (1) wire per lug.
2. One or two stranded copper wires of same size, or differing by two (2) gauge sizes.
3. Coil terminal wire size is #14 AWG maximum.

Approximate Dimensions In Inches Type HP NEMA Sizes 00, 0, 1 & 2 Outline Drawings

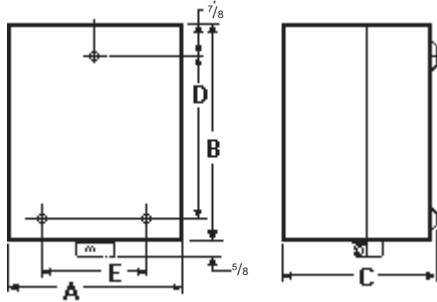

NEMA Type 1 Enclosure

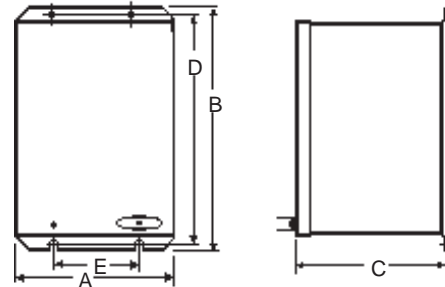

NEMA Type 4 & 12 Enclosures

Starter Type	NEMA Type 1 Enclosure										NEMA Type 4 & 12 Enclosure									
	Without Transformer					With Transformer					Without Transformer					With Transformer				
	A	B	C	D	E	A	B	C	D	E	A	B	C	D	E	A	B	C	D	E
HP&HPC	6 ³ / ₄	9 ¹ / ₂	6 ¹ / ₄	7 ³ / ₄	5	12 ⁵ / ₈	9 ¹ / ₂	6 ¹ / ₄	7 ³ / ₄	11	7 ¹ / ₄	11	6 ⁷ / ₈	10 ¹ / ₂	4	13 ¹ / ₈	11	6 ⁷ / ₈	10 ¹ / ₂	6
HPR&HPRC	12 ⁵ / ₈	9 ¹ / ₂	6 ¹ / ₄	7 ³ / ₄	11	12 ⁵ / ₈	13 ⁷ / ₈	6 ¹ / ₄	12 ³ / ₄	11	13 ¹ / ₈	11	6 ⁷ / ₈	10 ¹ / ₂	6	17	13	6 ⁷ / ₈	9	16

Type HPS NEMA Sizes 00, 0, 1 & 2 Outline Drawings

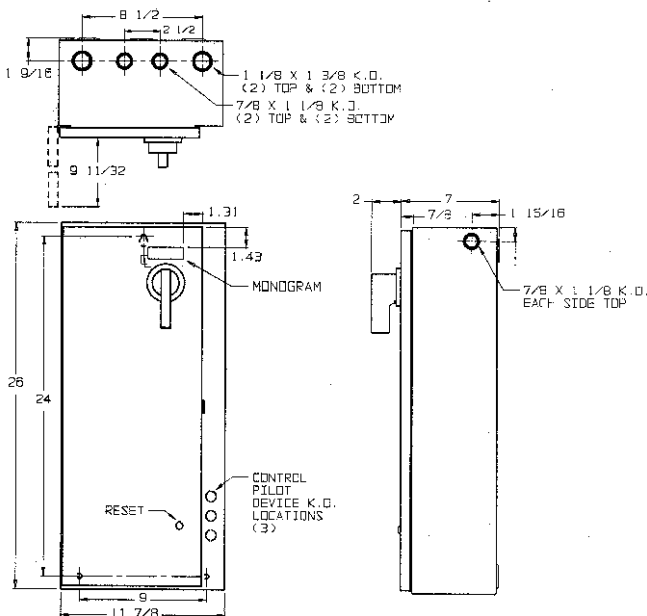

NEMA Type 1 Enclosure

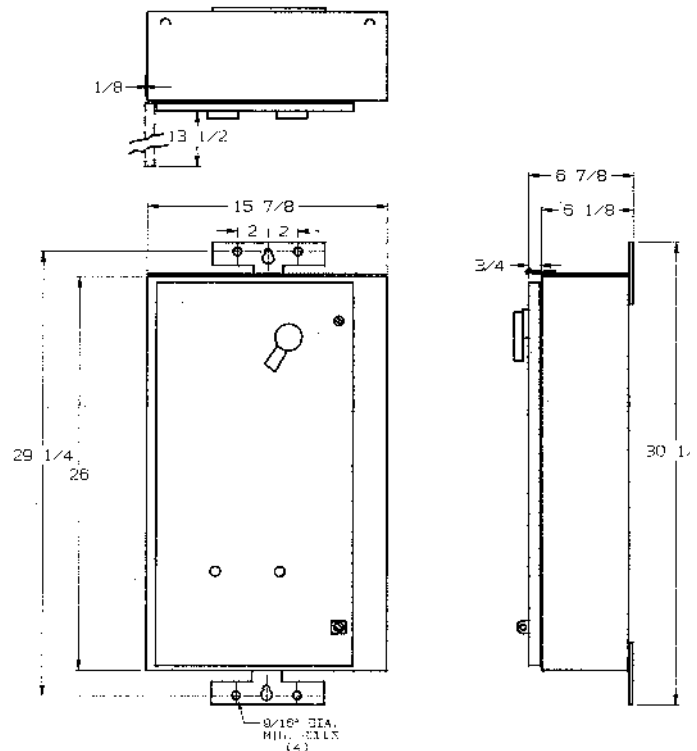

NEMA 3R-4&12 Enclosure

Wiring Diagram Type HP - Non-Combination Starter

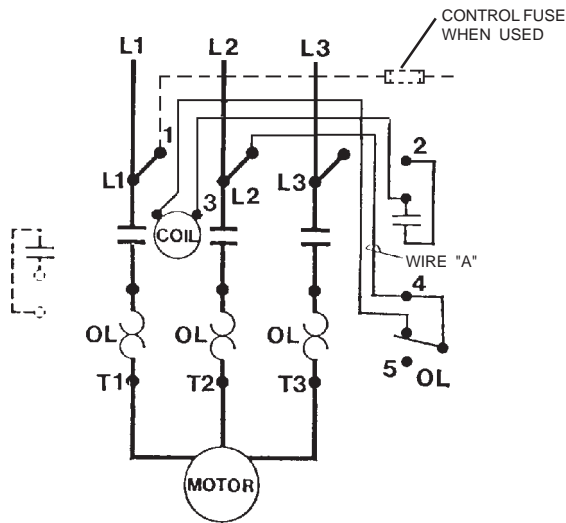

3 Pole, Three Phase

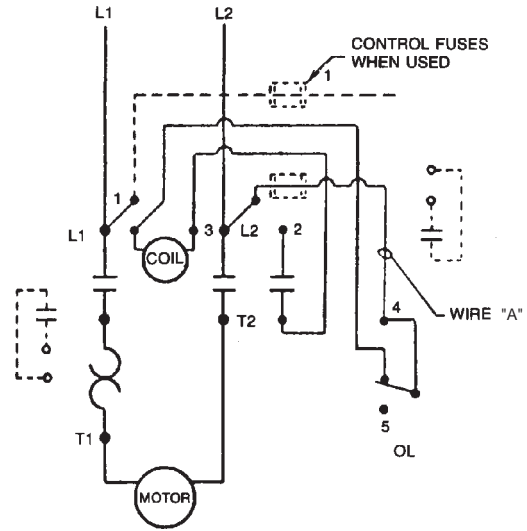

2 Pole, Single Phase

Connection For Pilot Devices

Cover Mounted Pilot Devices		3 Wire Control Remote Pilot Devices		<p>Automatic Reset Automatic reset operation should not be used with two wire control.</p> <p>Separate Control Remove wire "A" when it is supplied. Connect separate control lines to the "1" terminal on the pilot device and the "4" terminal on the starter.</p>
<p>Start-Stop Pushbutton</p>	<p>Pilot Light</p> <p>Connect To Coil Terminals</p>	<p>Momentary Contact Pushbutton</p>		
<p>Two Wire Contact Device</p> <p>To L.H. Coil Term</p>	<p>2 Position Selector Switch</p> <p>To L.H. Coil Term</p>	<p>Two or More Momentary Contact Pushbutton Stations</p>		
<p>3 Position Selector Switch (Remove Lead from Coil to Term No. 3)</p>	<p>2 Position Selector Switch (Remove Lead from Coil to Term No. 3)</p>			

0
2
3

Wiring Diagram Type HPR - Non-Combination Starters

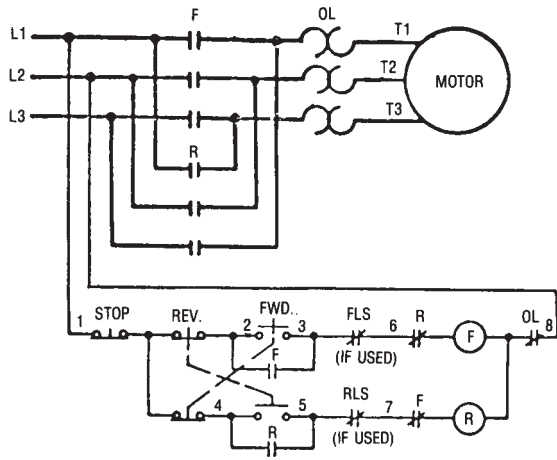

Elementary Diagram

Contactors "F" & "R" are Mechanically Interlocked

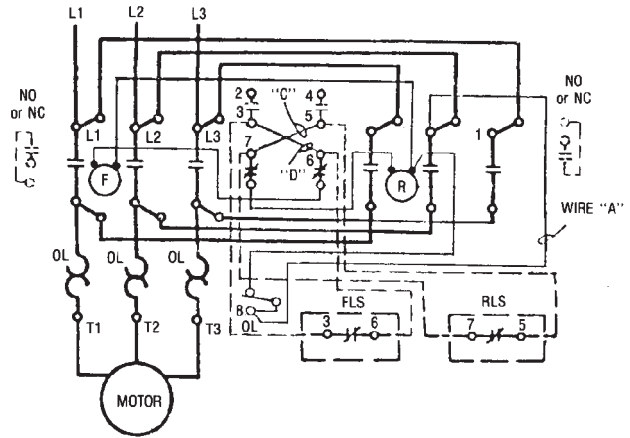

Wiring Diagram Front View

When Limit Switches are used, remove Jumpers "C" & "D" and connect per dotted lines.

Two Wire Control for Maintained Pushbuttons	Three Wire Control for Momentary Control Pushbuttons	<p>Automatic Reset Automatic reset operation should not be used with two wire control.</p> <p>Separate Control Remove wire "A" when it is supplied. Connect separate control lines to the "1" terminal on the pilot device and the "8" terminal on the starter.</p>
	<p>Pushbutton with Forward and Reverse Buttons Electrically Interlocked</p>	

0
2
3

Wiring Diagram Type HPF - Combination Starter

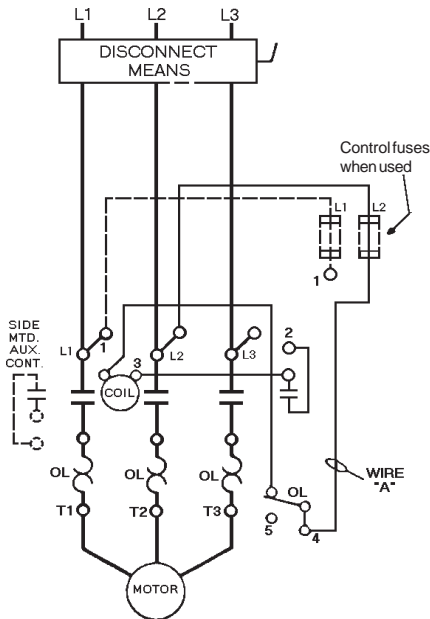

Without Control Transformer
(Wiring Diagram - Front View)

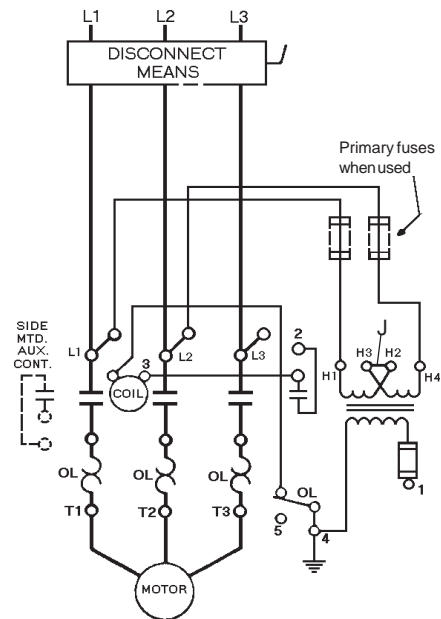

With Control Transformer
(Wiring Diagram - Front View)

Connection For Pilot Devices

Connections for Cover Mounted or Remote Pilot Devices			Dual voltage transformer is shipped as shown connected for higher voltages. Reconnect jumpers "J" per table for lower voltage.
<p>2 Position Selector Switch (Remove Lead from Aux. to Term No. 3)</p>	<p>3 Position Selector Switch (Remove Lead from Aux. to Term No. 3)</p>	<p>Connect to Coil Terminals</p> <p>Pilot Light</p>	
<p>Start-Stop Pushbutton</p>	<p>Two or More Momentary Contact Pushbutton Stations</p>	<p>Push-To-Test Pilot Light</p>	
		<p>Two Wire Control Device</p>	

Voltage	Connect	L1	L2
230	H1 to H3	H1	H4
	H2 to H4	H1	H4
460	H2 to H3	H1	H4
	All Single Primary Transformers	H1	H2

Automatic Reset
Automatic reset operation should not be used with two wire control.

0
2
3