



# MAINTENANCE AND INSTALLATION MANUAL

BULLETIN 7707 TYPE CV VACUUM CONTACTOR

NEMA SIZE 4 AND 200 AMP

CURRENT RATINGS 135A AND 200A

600V -1500V

Introduction	page 2
Inspection	page 3
Installation	page 3
Coil Replacement	page 4
Control Pak Replacement	page 7
Aux. Contact Assembly Installation	page 7
Vacuum Interrupter Phase Assembly Replacement	page 8
Contact Life Over-Travel Measurement	page 9
Cleaning and Maintenance	page 9
Vacuum Interrupter Integrity Test	page 10
Replacement Parts	page 11
Dimensions	page 12
Wiring	page 12

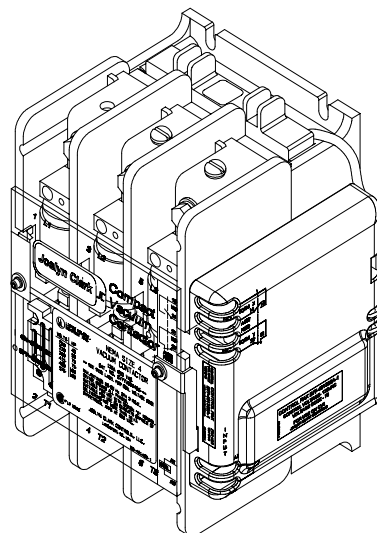

## Joslyn Clark Controls, LLC.

2013 W. Meeting Street, Lancaster, SC 29720-8842  
Phone 803-286-8491 Fax 803-285-0885  
<http://www.joslynclark.com>

**Note: Read all instructions before working on this equipment.**

## **DANGER**

WARNING. Risk of electric shock.  
AVERTISSEMENT. Risque de choc électrique.

Disconnect all sources before working on this equipment.  
Couper toutes les sources d'alimentation avant de travailler sur cet appareil

### **HAZARD OF ELECTRICAL SHOCK OR BURN.**

POWER MUST BE DISCONNECTED FROM THE CONTROLLER AND CONTACTOR PRIOR TO PERFORMING ANY INSTALLATION OR MAINTENANCE. THE EQUIPMENT HAS BEEN DESIGNED TO PERMIT MAINTENANCE AND/OR TESTING ON THOSE COMPONENTS THAT ARE DISCONNECTED FROM THE MAIN POWER. WHEN PERFORMING THIS WORK, EXTREME CAUTION MUST BE EXERCISED IN VIEW OF THE PRESENCE OF HAZARDOUS VOLTAGE.

The following precautions must be studied and followed during installation, operation, and servicing of this equipment.

1. Read this service bulletin prior to installation or operation of this equipment.
2. If motor controllers and/or contactors are to be stored prior to installation, they must be protected from the weather and be kept free of condensation and dust.
3. Use care when moving or positioning contactors (even when boxed) as they contain devices and mechanisms, which may be damaged by rough handling.
4. Be sure all barriers and terminal covers are in place before operating the contactors.
5. Only authorized personnel should be permitted to operate or service the contactors and controllers.

### **INTRODUCTION**

This instruction manual covers the description, inspection, installation, operation and maintenance of Joslyn Clark's USAVAC CV compact series of low voltage vacuum contactors.

CV77U030406 - 600V NEMA size 4 135A 3 Pole Contactor

CV77U032006 - 660V 200A 3 Pole Contactor

CV77U031615 - 1500V 200A 3 Pole Contactor

In addition, the contactors are available and may be supplied as open type or enclosed combination or non-combination starters, full or reduced voltage types. Mechanically interlocked reversing contactors or starters, open or enclosed types. These contactors are rated both by current and voltage as defined above, and must be applied at all times with coordinated short circuit protection devices in accordance with national or local electrical codes.

## PACKAGE CONTENTS

1. CV Compact Vacuum Contactor
2. Service Bulletin

## INSPECTION – UNPACKING

Before the contactor is placed in service, check carefully for shipping damage. Any damage should be reported to the carrier within (3) three days of receipt. For overseas deliveries, it is important to obtain a certificate of examination from the nearest insurance inspector and photographs of the damage. This and other evidence should accompany any communication to the insurance company or shippers. In the event equipment is to be returned to the factory, contact Joslyn Clark Customer Service Department or our local representation for return authorization. A returned material authorization (RMA) number will be issued which should appear on all correspondence on the returned container.

The USAVAC Vacuum Contactor is shipped in a shock resistant filled cardboard box. The following steps should be taken when unpacking the contactor:

1. Check the packing list against the order to make sure the shipment is complete and components are received.
2. Examine the shipping box before unpacking the contactor to make sure it has not been damaged in shipment. If the shipping box is damaged, pay particular attention when unpacking to see if the contents are also damaged. Notify the carrier if damage is found and notify your local Joslyn Clark order field sales office of damage.

## INSTALLATION INSTRUCTIONS

The vacuum contactor may be used in any mounting plane. In any non-horizontal mounting plane, the top of the contactor should point up (so that the label appears right-side up). Care should be taken to insure that the mounting hardware does not warp the mechanism frame. If the surface of the contactor to which the contactor is mounted is twisted, shims should be used to correct the condition. Any appreciable degree of end to end twist will result in phase to phase discrepancies and timing of the main contact could cause increased pickup in control voltage values.

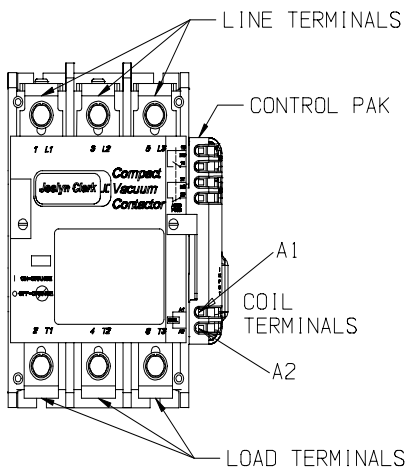

**FIGURE 1**

1. FIGURE 1 illustrates the field terminals for line and load terminations. Mount the contactor with the hardware specified in FIGURE 2. Loosely install the (4) mounting bolts into the intended mounting surface. Torque the mounting bolts to 50-75 inch-lbs.
2. Connect control wires to the vacuum contactor control terminals A1 and A2 located on the Control Pak using #18 to #12 gauge 75°C stranded copper or tin stranded copper wire tightening screw terminals

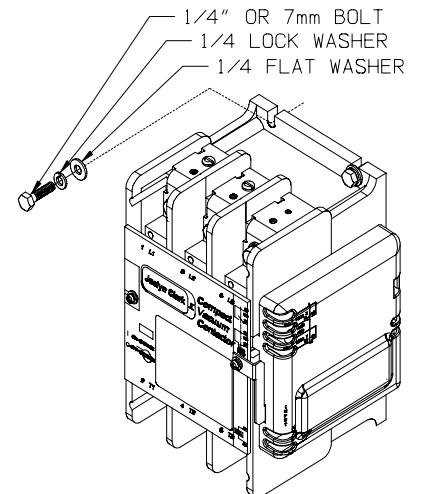

**FIGURE 2**

- to 7 inch lbs. torque.
3. Using 75°C wire copper cable, connect the line and load conductors to the main terminals (FIGURE 1) and proper phase rotation, tighten the main terminal bolts to 11 foot lbs. torque.
4. Check all connections for accuracy and mechanical connection before energizing.

## COIL REPLACEMENT INSTRUCTIONS

### **DANGER**

**DE-ENERGIZE THE CONTACTOR AND ISOLATE FROM ALL CONTROL AND POWER SOURCES.**

1. Disconnect all power cables (or bus work) and all control wiring to the contactor.
2. Remove the contactor from its mounted location. The contactor is best serviced in the tabletop position.
3. Remove the cover attachment screws from the contactor and remove the cover (FIGURE 3A).
4. Disconnect the two wire leads from the Coil to the Control-Pak. Remove the Control Pak from the contactor and set on tabletop (FIGURE 3A).

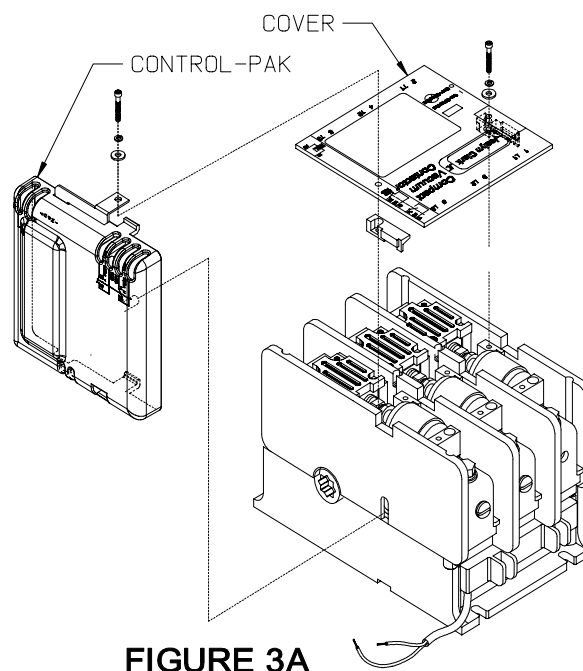

5. Remove the (6) screws that secure the Upper Housing to the Lower Housing by first removing the (4) outer screws and then (2) center screws. **NOTE-** removing the center screws will release the Return Springs. Carefully remove the Upper Housing leaving the Return Springs in the Lower Housing (FIGURE 3B).

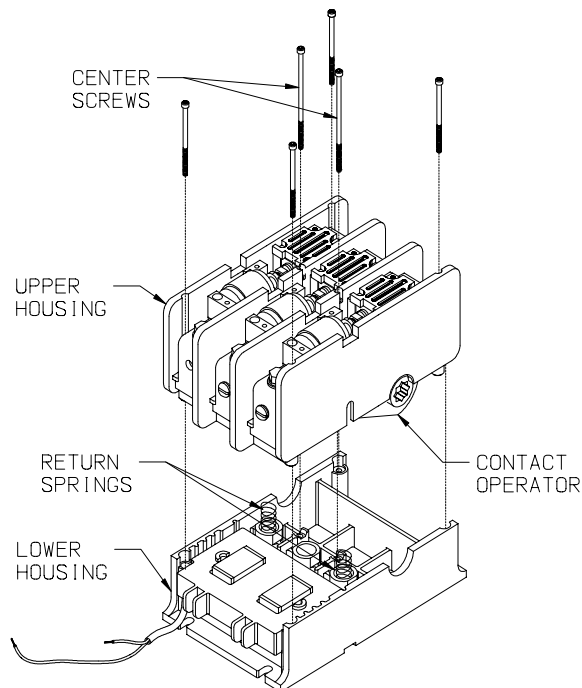
**FIGURE 3B**

6. Remove and replace the coil. Ensure that the Shim Plate remains in the proper position between the magnet core and coil (FIGURE 3C).

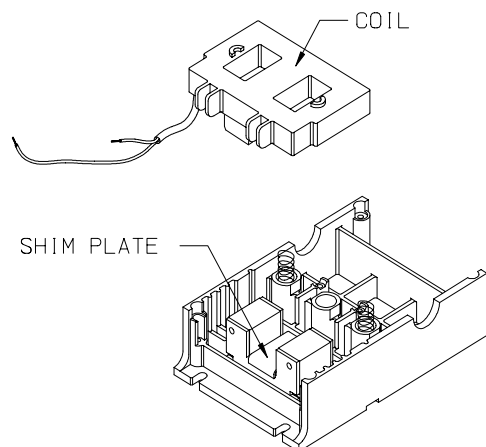
**FIGURE 3C**

- Carefully replace the Upper Housing, ensuring that it is orientated correctly and that the Return Springs are seated on the outer two bumps on the bottom of the Contact Operator (FIGURE 3D). Replace the (6) screws that secure the Upper Housing. Tighten the screws equally in a diagonal pattern approximately two turns at a time until tightened to 15-20 inch lbs. in the same diagonal pattern (FIGURE 3A).

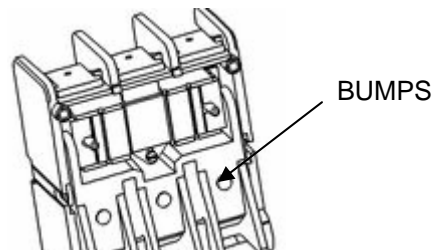
**FIGURE 3D**

- Reinstall the Control Pak (FIGURE 3E). First, insert the lower tab into the recess on the side of the contactor base. With proper installation, the Control Pak Actuator will fit into the hole in the center of the brass stud - which can be viewed through the slot in the side of the contactor housing. Using a thin screw driver or other thin rod, push the Control Pak Actuator up or down as necessary to insert it into the brass stud mentioned.

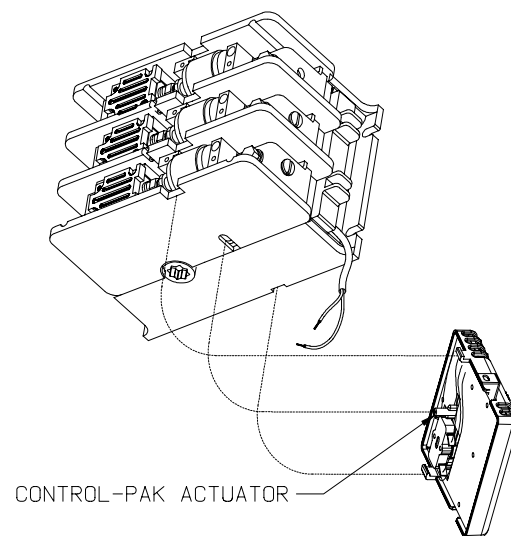
**FIGURE 3E**

- Reinstall the cover and secure it with the original mounting hardware. Tighten the four screws in a diagonal pattern to 12 inch lbs. (FIGURE 3A).
- Reattach the coil wire leads to the Control Pak (tighten to 7 inch lbs)
- Reinstall the device and reconnect any auxiliary control wires. Reconnect the line and load conductors and tighten the main terminal hardware and bolts to 11ft. lbs.

## CONTROL PAK REPLACEMENT INSTRUCTIONS –

### **DANGER**

**DE-ENERGIZE THE CONTACTOR AND ISOLATE FROM ALL CONTROL AND POWER SOURCES.**

1. Disconnect all control wiring to the Control-Pak.
2. Remove the cover attachment screws from the contactor and remove the cover (FIGURE 3A).
3. Remove the Control Pak from the contactor (FIGURE 3A).
4. Install the new Control Pak (FIGURE 3E). First, insert the lower tab into the recess on the side of the contactor base. With proper installation, the Control Pak Actuator will fit into the hole in the center of the brass stud - which can be viewed through the slot in the side of the contactor housing. Using a thin screw driver or other thin rod, push the Control Pak Actuator up or down as necessary to insert it into the brass stud mentioned.
5. Reinstall the cover and secure it with the original mounting hardware. Tighten the four screws in a diagonal pattern to five inch lbs. (FIGURE 3A).
6. Reconnect all control wiring removed per Step 1. Tighten to 7 inch lbs.

## AK1 or AK3 (AUXILIARY CONTACT ASSEMBLY) INSTALLATION INSTRUCTIONS

### **DANGER**

**DE-ENERGIZE THE CONTACTOR AND ISOLATE FROM ALL CONTROL AND POWER SOURCES.**

1. If replacing the existing AK, disconnect all control wires from the auxiliary terminals.
2. Remove the cover attachment screws from the contactor and remove the cover (FIGURE 3A).
3. Install the new AK (FIGURE 5). First, insert the lower tab into the recess on the side of the contactor base. With proper installation, the AK Actuator will fit into the hole in the center of the brass stud - which can be viewed through the slot in the side of the contactor housing. Using a thin screw driver or other thin rod, push the AK Actuator up or down as

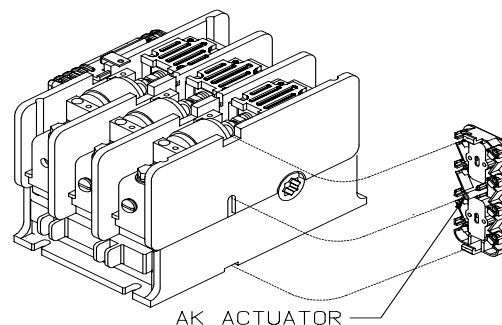

**FIGURE 5**

necessary to insert it into the brass stud mentioned.

4. Reinstall the cover and secure it with the original mounting hardware. Tighten the four screws in a diagonal pattern to five inch lbs. (FIGURE 3A).
5. Connect all control wiring (Tighten to 7-9 inch lbs).

## VACUUM INTERRUPTER PHASE ASSEMBLY REPLACEMENT INSTRUCTIONS

### **DANGER**

**DE-ENERGIZE THE CONTACTOR AND ISOLATE FROM ALL CONTROL AND POWER SOURCES.**

1. Disconnect all power cables (or bus work) and all control wiring to the contactor.
2. Remove the contactor from its mounted location. ***The contactor is best serviced in the tabletop position.***
3. Remove the cover attachment screws from the contactor and remove the cover (FIGURE 3A).
4. Remove the Control Pak from the contactor and set on tabletop (FIGURE 3B).
5. Locate the replacement Interrupter Phase Assembly that needs to be replaced. ) ***It is recommended that all three interrupters be replaced at the same time.***
6. Remove the hardware that secures the shunt to the terminal (FIGURE 6A).
7. First remove the hardware securing the Cam Cover, then remove the hardware securing the Interrupter Phase Assembly. Note the position of the shunt prior to removing the Interrupter Phase Assembly. Carefully remove the Interrupter Phase Assembly (FIGURE 6B).
8. Place the new Interrupter Phase Assembly into the upper housing. Be sure that the Cams are properly seated around the Contact Operator. Thread the Shunt through the housing and Contact Operator, following the Shunt path (FIGURE 6C). Replace the hardware securing the Interrupter Phase Assembly (FIGURE 6B). Tighten screws to 60-80 inch lbs.
9. Attach the Shunt to the Load Terminal by placing the Shunt against the Terminal with the flat washer and lock washer between the Shunt and the head of the bolt (FIGURE 6A), and tighten until the lock washer is fully compressed (or up to 60 inch-pounds).
10. Replace the Cam Cover and hardware (tighten to 60-80 inch lbs).
11. Reinstall the Cover and secure it with the original mounting hardware. Tighten the four screws in a diagonal pattern to five inch lbs. (FIGURE 3A).

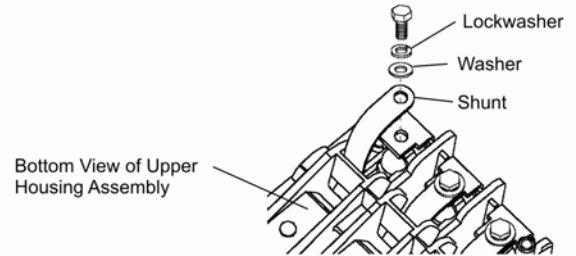

**FIGURE 6A**

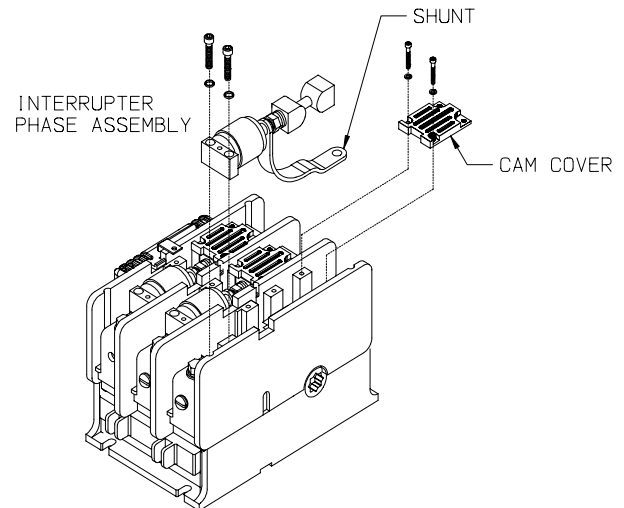

**FIGURE 6B**

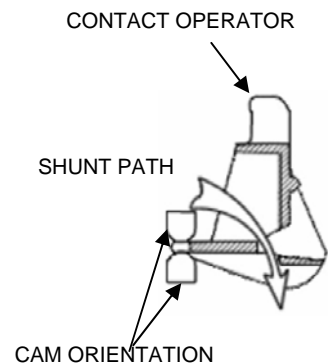

**FIGURE 6C**

12. Reattach the coil wire leads to the Control Pak (tighten to 7 inch lbs)
13. Reinstall the device and reconnect any auxiliary control wires. Reconnect the line and load conductors and tighten the main terminal hardware and bolts to 11 ft. lbs.

### **CONTACT LIFE OVER TRAVEL MEASUREMENT**

The purpose of this measurement is to determine how much electrical life remains on the contact and is performed using a standard wire gauge in a “go, no go” check.

1. De-energize the contactor and isolate from all power sources. The control source can be maintained if coming from a separate supply or if taken from a line to line connection by application then an additional control source needs to be connected to terminals A1 and A2. Re-energize the contactor insuring that the main power circuits are open and isolated.
2. Remove Phase Cover as described earlier to access inspection area (FIGURE 7).
3. When the contactor is closed, a gap occurs, and this gap should accept a standard wire (.010”) gauge. If the gauge can be inserted in the space then sufficient life remains for an additional 100,000 operations. Check all phases.
4. If the .010” wire gauge cannot be inserted into this gap with the contactor energized, then over travel has been exhausted and thus contact life used up. The contactor should be replaced.

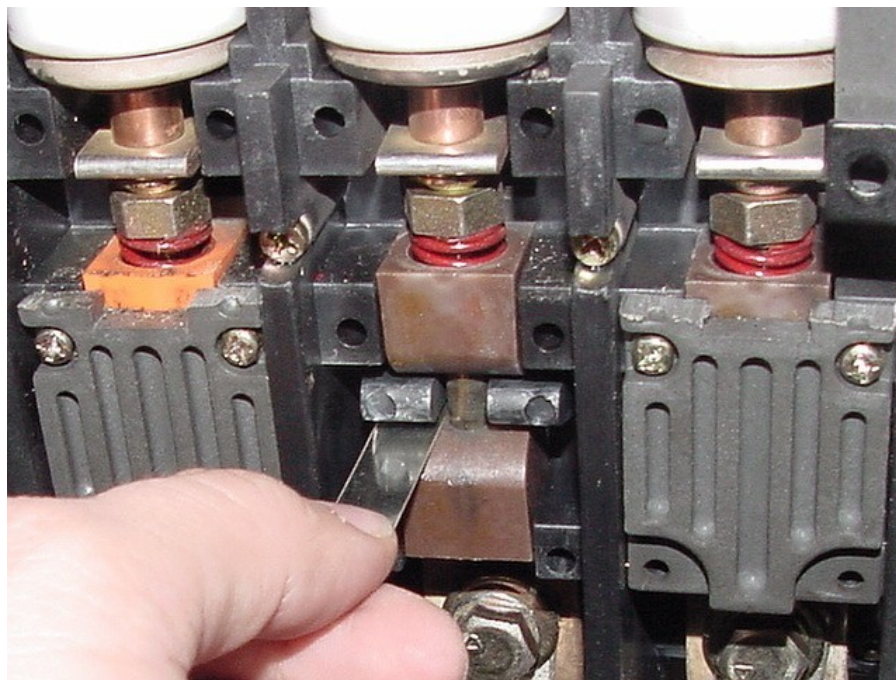

**FIGURE 7**

### **CLEANING AND MAINTENANCE**

1. The vacuum contactor requires no adjustment. Preventative maintenance is recommended on a routine basis, once every twelve months, dependent upon the environment that the contactor is exposed to. In general, maintenance consists of keeping the device free of dirt and dust and ensuring the power and control terminals are tight.
2. Maintenance should verify the mechanical operation of the device for freedom of movement. Clean dirt from the surfaces. Pay particular attention to molded parts and

tracking surfaces. Foreign materials on these surfaces should be removed by vacuum or wiping (DO NOT USE COMPRESSED AIR).

## VACUUM INTERRUPTER INTEGRITY TEST

### **DANGER**

**EXERCISE CAUTION WHILE PERFORMING HIGH VOLTAGE POTENTIAL TESTS. HIGH VOLTAGE IS LETHAL.**

1. A high potential test will determine the di-electric strength and condition of the vacuum interrupter. A high potential test should be performed on each vacuum interrupter phase in sequence and should be performed approximately once every twelve months.
2. The vacuum interrupter integrity test should be performed if the contactor has been known to be exposed to fault conditions either phase to phase or phase to ground.
3. When doing this check, make visual inspection for physical evidence of stress, distorted discolored or cracked interrupters.
4. A contact resistance test can be done as defined below or if preferred a high potential test; di-electric test should be performed as follows.

## CONTACT RESISTANCE

A contact resistance test can be performed using a micro-ohmmeter. This test determines the condition of contact surfaces. With the contactor closed, the resistance across the terminals should be less than 200 micro-ohms. If higher contact resistance values are measured then a high potential test should be performed, as follows:

## HIGH POTENTIAL TEST

### **DANGER**

The following test should be performed using a 50/60 Hz test set. Where the voltage is continuously variable up to at least 20 kV. X-radiation at this level is negligible. However, personnel should not be closer than ten feet to the interrupter and the test cables to avoid high voltage shock hazards. The contactor should be free of dust and other contaminants before conducting this test.

1. Disconnect the line and load conductors from the contactor.
2. Connect the leads of the test set across the interrupter terminals with the contactor in the open position.
3. Slowly raise the voltage to 7.5KV and hold for 15 seconds.
4. The leakage current should not exceed 5 MA during the test and any tripping of the test set circuit protector during the test should be repeated two to three times. If it becomes impossible to reach the 7.5KV level indicates then the interrupter needs to be replaced, and should be replaced by utilizing a Joslyn Clark replacement phase assembly kit.

**REPLACEMENT PARTS**COIL

<b>CAT SUFFIX #</b>	<b>JCC CAT.#</b>	<b>DESCRIPTION</b>
-76	A77-460915A-1	110/120V
-26	A77-460915A-2	220/240V
-35	A77-460915A-3	380/415V
-46	A77-460915A-4	440/460V
-125	A77-460915A-5	125V DC
-250	A77-460915A-6	250V DC

CONTROL PAK

<b>CAT SUFFIX #</b>	<b>JCC CAT.#</b>	<b>DESCRIPTION – 50/60 HZ</b>
-76	A77-460916A-1	110/120V
-26	A77-460916A-2	220/240V
-35	A77-460916A-3	380/415V
-46	A77-460916A-3	440/460V

PHASE ASSEMBLY

	<b>JCC CAT#</b>
CV4 200A	A77- 457211A

AUXILIARY AK KITS

<b>JCC CAT#</b>	<b>DESCRIPTION</b>	<b>RATINGS</b>
A77-460917A-1	AK1 (Standard) – 2N/O 2N/C	600V 10A AC Standard
A77-460917A-2	AK3 (Low Power) - 2N/O 2N/C	5V DC 10MA DC
A77-460917A-4	AK-STD	
A77-460917A-5	AK4 250V DC	

LUG KIT

	<b>JCC CAT#</b>
#2-600MCM	KVC6-2

**DIMENSIONS**

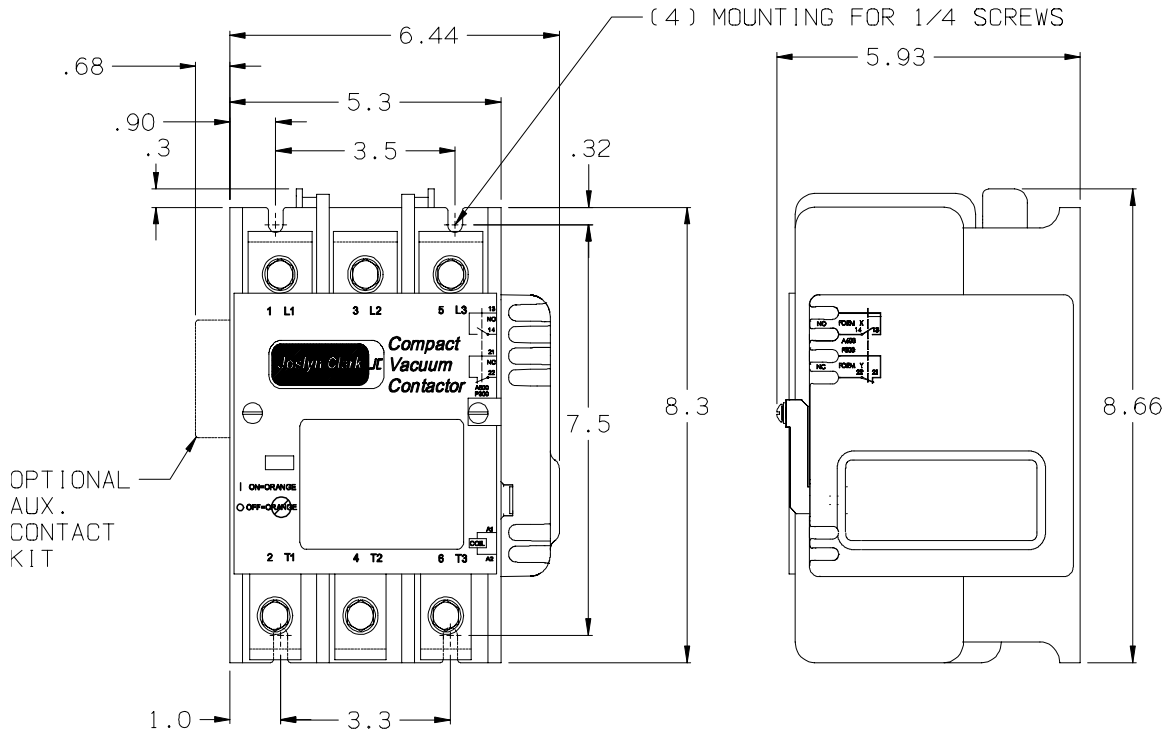

**WIRING**

SCHEMATIC

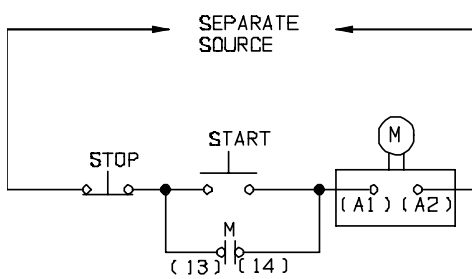

WIRING DIAGRAM

