

Joslyn Clark



SERVICE BULLETIN VC7707

USAVAC VACUUM CONTACTOR
Instruction Manual 480V, 1.5KV 3.3KV
160A, 320A, 600A & 1000A

Inspection
General Description
Operation
Installation
Maintenance

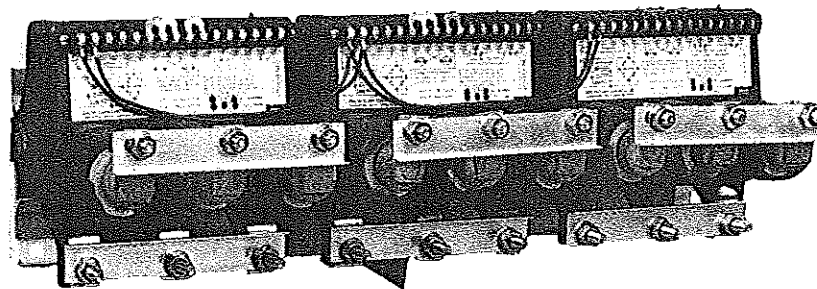
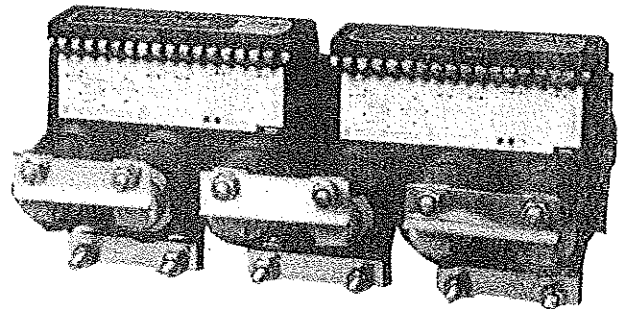
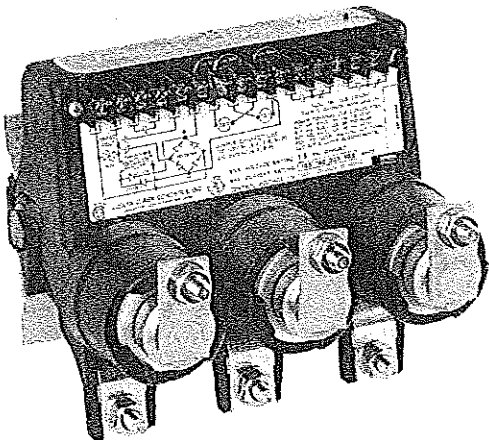

Joslyn Clark Controls, Inc.

PO Box 945, Rt. 4 Rock Hill Hwy, Lancaster, SC 29720, Phone 803-286-8491 Fax : 803-285-0885

NOTE: READ ALL INSTRUCTIONS BEFORE WORKING ON THIS EQUIPMENT.

PRECAUTIONS

DANGER

HAZARD OF ELECTRICAL SHOCK OR BURN

POWER MUST BE DISCONNECTED FROM THE CONTROLLER AND CONTACTOR PRIOR TO PERFORMING ANY INSTALLATION OR MAINTENANCE. THE EQUIPMENT HAS BEEN DESIGNED TO PERMIT MAINTENANCE AND/OR TESTING ON THOSE COMPONENTS THAT ARE DISCONNECTED FROM THE MAIN POWER. WHEN PERFORMING THIS WORK, "EXTREME CAUTION" MUST BE EXERCISED IN VIEW OF THE PRESENCE OF HAZARDOUS VOLTAGE.

INTRODUCTION

This Instruction Manual Covers the description inspection, installation, operation and maintenance of Joslyn Clark's "USAVAC" Vacuum Contactors.

General Description

The "USAVAC" Vacuum Contactors are available in the following three phase ratings:

Voltage	Current Ratings			
1500V	160	320	600	1000
3300V	160	320	600	1000

They are also available as high current switches in the following single pole and single phase double pole ratings:

Single Phase SinglePole				
1500V	450A	1000A	1500A	2500A
3300V	450A	1000A	1500A	2500A

Single Phase DoublePole			
1500V	450A	1000A	1500A
3300V	450A	1000A	1500A

The following list of "PRECAUTIONS" must be studied and followed during installation, operation and servicing of the equipment.

1. Read this service bulletin prior to installing or operating the equipment.
2. If motor controllers and/or contactors are to be stored prior to installation, they must be protected from the weather and be kept free of condensation and dust.
3. Use extreme care when moving or positioning contactors (even if boxed) as they contain devices and mechanisms which may be damaged by rough handling.
4. Be sure all barriers and terminal covers are in place before operating controllers.
5. Only authorized personnel should be permitted to operate or service the contactors and controllers.

In addition the contactors are available, and may be supplied as open type, or enclosed combination or non combination starters full or reduced voltage types. Mechanically interlocked reversing contactors or starters again open or enclosed types. These contactors are rated 240-1500V. Ac 50-400Hz. or 1501-3300 50-400Hz. these latter designs utilize insulated terminal boots on ALL phases rated 160 and 320A and center phases for 600 & 1000A ratings. The 160 - 320 - 600 & 1000A contactors have interrupt rating of 4400 - 5000 - 6000 & 6000A respectively. The contactors require to be applied at all times with coordinated short circuit protection devices in accordance with N.E.C. Codes.

INSPECTION - UNPACKING

Before the contactor is placed in service, check carefully for shipping damage. Any damage should be reported to the carrier within (3) three days of receipt. For overseas deliveries, it is important to obtain a certificate of examination from the nearest insurance inspector and photographs of the damage. This and other evidence should accompany any communication to the insurance company or shippers. In the event equipment is to be returned to the factory, contact Joslyn Clark Customer Service Department or local representation for return authorization. A returned material authorization (RMA) number will be issued which should appear on all correspondence and the returned container.

The USAVAC Vacuum Contactor is shipped in a shock resistant foam filled cardboard box. The following steps should be taken when unpacking the contactor:

1. Check packing list against the order to make sure shipment is complete and components are received. Some contactors require phase insulating boots (check contactor electrical decal).
2. Examine shipping box before unpacking the contactor to make sure it has not been damaged in shipment. If shipping box is damaged, pay particular attention when unpacking to see if contents are also damaged. Notify carrier if damage is found. Also, notify your local Joslyn Clark field sales office of damage.

The contactor is a modular design using high strength molded housings. The construction has very limited hardware. The contactors can be assembled or dismantled without the use of any tools. The principle parts are:

1. Pole or Phase Assembly
2. Control Module
3. Drive Shaft and Base

PHASE ASSEMBLY (FIGURE 1)

The modular design allows two, three, or other multi-pole configuration to be easily assembled. The pole assembly contains the vacuum interrupter, its protective housing, pull rod, opening and overtravel springs. The assembly is factory set and has no requirement for adjustment or resetting. Should the interrupter need replacing, a replacement factory set assembly is utilized and is simply slipped onto the main drive shaft.

CONTROL MODULE (FIGURE 1)

The control module is a removable assembly containing all control components, ie., coils, rectifier, economizing circuit, auxiliary switches and terminal board. The modular design allows for easy removal and quick replacement of a spare module. The removed control module can then be more easily checked in a service area or workshop.

DRIVE SHAFT AND BASE ASSEMBLY (FIGURE 1)

These parts are designed to hold the modular components together to form a composite assembly.

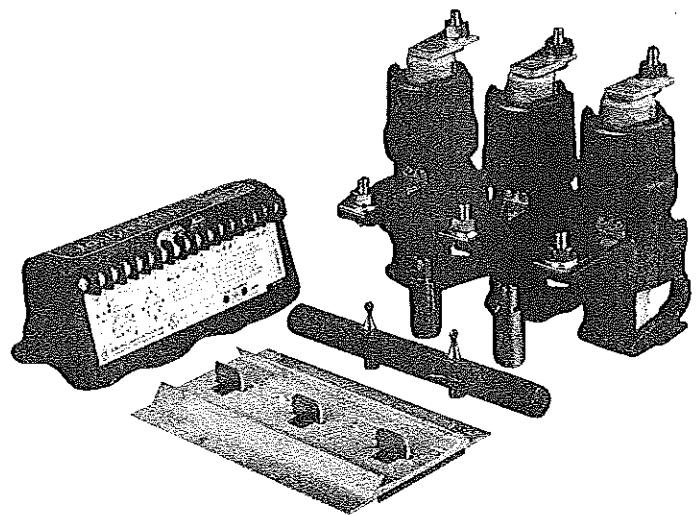

FIGURE 1

OPERATION

The vacuum interrupter contacts are held by an opening spring held in compression, and one spring is provided per interrupter or pole assembly. Two closing coils are provided per control module, are d.c. activated and designed to overcome the force of the opening springs. During closing, the main contacts touch and additional overtravel force is provided by an additional spring held in compression mounted in the interrupter stem. The overtravel spring, one per pole or interrupter, provides additional contact force. The overtravel allows for contact erosion and therefore provides a self-adjusting feature should contact erosion occur.

Contact pressure is applied immediately behind the moving contact, which eliminates contact bounce, and provides considerable stored energy to open the contacts before the armature mechanism begins to move. In the final closing movement of the armature, the economizing circuit is activated. This contact is housed in the molded dust-protected module housing and requires no adjustment. Activation of the economizing circuit reduces the power consumption in the "hold in" mode to 8.7 watts per module. The heat dissipation is extremely low, to maximize component life.

NOTES

1. RECOMMENDED CONTACTOR MOUNTING HARDWARE 5/16" (NOT SUPPLIED).
2. TERMINAL HARDWARE 3/8" (SUPPLIED)

CONNECTIONS

Maximum cable sizes are specified on the electrical decal. Cable supports should be used where large cables might transmit large mechanical loads to the contactor terminals. Insulated terminal boots must be used when provided. (Refer to Terminal Boots). Connect lugs to contactor line and load terminals using the provided hardware.

CAUTION

TO PREVENT DAMAGE AND TERMINAL DEFORMATION USE DOUBLE WRENCHES TO CONNECT LUGS TO LINE/LOAD TERMINALS. SECURE LUG WHILE TIGHTENING CABLE. DO NOT WRENCH CABLE OR LUG BY PULLING ON CABLE WHEN LUG IS TORQUED DOWN.

Torque lug connection bolts to 20 ft. lbs. If box type lugs are used, re-torque lug connection bolts after clamping cable into lug. See Table 1 for lug torque information when using type KVCL lug kits.

**TABLE 1 - KVCL
LUG KITS (OPTIONAL) 3 LUGS/KIT**

Contactors Amp. Rating	160A	320A	320A	600A (2 kits req'd)
Lug Kit	KVCL250	KVCL500	KVCL600	KVCL500
Cable Size	#6-250MCM	#4-500MCM	#2-600MCM	#4-500MCM
Lug Torque	22 ft. lbs.	31 ft. lbs.	31 ft. lbs.	31 ft. lbs.

TERMINAL BOOTS 1.5KV RATINGS

Contactors rated 160A and 320A, 3 Phase are provided with insulating terminal boots on center phase only and must be used when cable or bus is installed. See table 2 for replacement boots.

BOOT INSTALLATION PROCEDURE

1. Terminal boots are required on the center pole of the 160A and 320A contactors only. Boots are not required on the 600A or 1000A contactors.
2. Remove boot from contactor and cut end of boot to make an opening just big enough for conductor to slide through (See Figure 2).
3. Slide boot down conductor and terminate conductor on contactor (Refer to Connections)
4. Slide boot back onto contactor so that it is completely seated as shown in Figure 2.
5. Terminal boots are sized according to the maximum cable size to be used on the contactor. See Table 2.

TABLE 2 - TERMINAL BOOTS

Contactor Ampere Rating	160A	320A
Maximum Cable Size	250MCM	600MCM
Line Side Terminal Boot	KVC-UB1	KVC-UB1
Load Side Terminal Boot	KVC-UL1	KVC-UL1

6. Terminal boots are required on all phases (poles) of contactors rated 1501 - 3300V. On 160A & 320 ratings and center phase only of 600A (2 boots) or 1000A (3 boots) contactor 3 phase and one pole only of special purpose contactors.
ExSVC77U014533-76

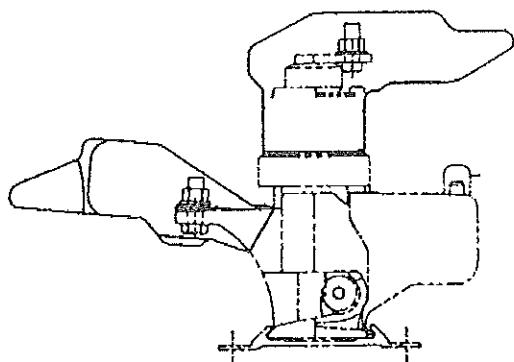

FIGURE 2

CONTROL POWER

Contactors are shipped configured for 120 volt ac. Figure 4 shows contactor schematic for both 120 and 240 volt ac input power. If input power is 240 volt ac, then remove jumpers between 7 and 8, and between 9 and 10. Reconnect both jumpers (to avoid losing one) between terminal points 8 and 9. Jumper between 6 and 7 should remain at all times. After terminal jumpers are properly configured connect either 120 or 240V ac control power to terminals 1 and 2 (See Figure 3).

TERMINALS 1 & 2

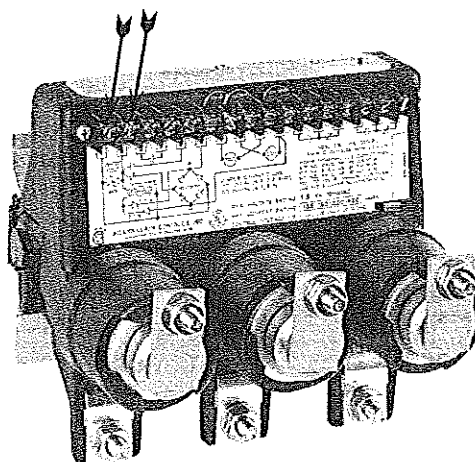

FIGURE 3

Figure 4 also shows 120vac, 10A auxiliary contacts (2 form C & 1 N.O.) for customer use. The "M" contact connected to terminal 5 is not an isolated contact and should be used only for a "Run" pilot light connected between terminals 2 and 5.

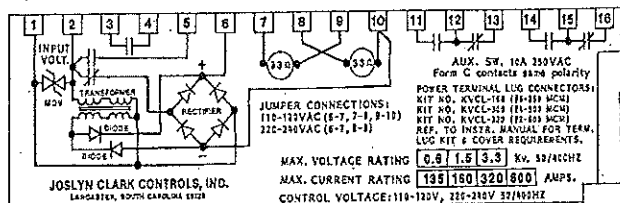
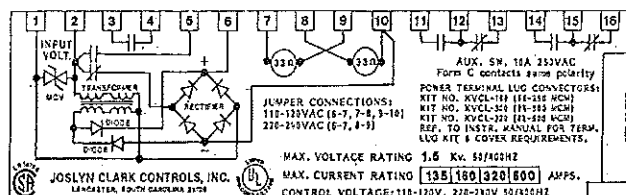

FIGURE 4

MAINTENANCE

DANGER

HAZARD OF ELECTRICAL SHOCK OR BURN

ALL POWER SHOULD BE DISCONNECTED FROM THE CONTROLLER EQUIPMENT PRIOR TO PERFORMING ANY TROUBLESHOOTING OR MAINTENANCE WORK ON THE CONTACTOR. HOWEVER, THE EQUIPMENT HAS BEEN DESIGNED TO PERMIT MAINTENANCE AND/OR TESTING ON THE CONTACTOR AFTER IT HAS BEEN ISOLATED FROM THE MAIN POWER. WHEN PERFORMING THIS WORK, EXTREME CAUTION MUST BE EXERCISED IN VIEW OF THE PRESENCE OF HAZARDOUS VOLTAGE.

IT IS RECOMMENDED THAT CONTACTOR BE REMOVED FROM CONTROLLER SECTION FOR ADDITIONAL SAFETY AND EASE OF MAINTENANCE.

The contactor is designed for long life with minimal maintenance. The mechanical life is at least three million and electrical life on normal motor switching is at least one million operations. An operation is considered as one closed and one open operation.

The contactor requires no adjustments. Preventative maintenance is at least suggested to be done on a routine basis through a general inspection of the contactor every twelve months. This should involve mechanically operating the device for freedom of movement and a cleanliness check with regard to dust or other contaminants.

The interrupters are well protected from mechanical damage. The phase assembly has anti-torque and over-compression features that prevent possible damage to the flexible bellows at any time in the interrupter's life.

CLEANING

Clean all dirt from the contactor. Pay particular attention to molded parts and tracking surfaces. Foreign materials on these surfaces should be removed.

CONTACT TIP GAP MEASUREMENT

(Figure 5 & 6)

The remaining electrical life can be checked by measuring overtravel. This can be done electrically or mechanically without dismantling or requiring the use of special tools (a wire gauge can be used).

DANGER

EXISTING CONTROL POWER WIRING MUST BE DISCONNECTED FROM TERMINALS 1 AND 2 TO PREVENT POSSIBLE FEEDBACK OF VOLTAGE TO CONTROL POWER TRANSFORMERS. FAILURE TO DO SO COULD LEAD TO EXPOSURE OF PERSONNEL TO POTENTIALLY HAZARDOUS VOLTAGES.

1. Remove power connections on fixed terminal "A" on all phases (Refer to Connections under Installation).

CAUTION

FAILURE TO REMOVE POWER CONNECTIONS COULD LEAD TO EXCESSIVE FORCE ON VACUUM BOTTLE ASSEMBLY

2. Unscrew all caps by rotating counterclockwise 1/2 to 3/4 of a turn. (Do Not Unscrew Further).
3. Close the contactor by either hand rotation with 1/4 inch hexagonal key (Allen wrench) on shaft at "B" or electrically by providing control isolated test power supply voltage on terminals "1 and 2".

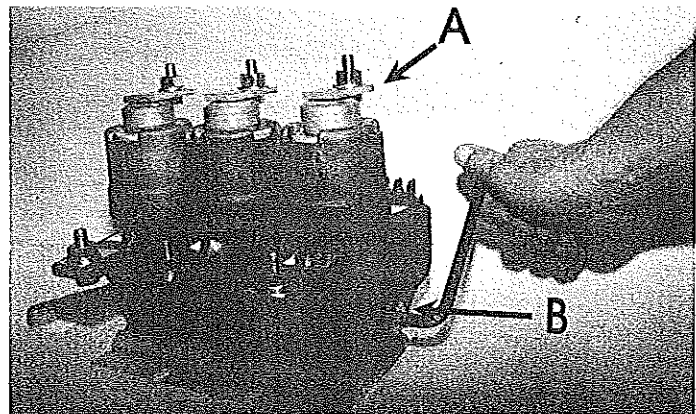

FIGURE 5

4. Closing the contactor will lift the interrupter by its overtravel distance. Screw cap down clockwise to interrupter and stop when resistance is felt, do not tighten further.

5. De-energize or release hexagonal key at point "B" so that the contactor is now in the open position.

6. The gap between the top of the interrupter and cap (See Figure 6) is remaining overtravel and represents remaining electrode life. This can be measured with a wire gauge and must not be less than .010". An alternative measurement is, that when retightening caps clockwise, they must be able to be rotated at least 15°. If less than these figures, erosion is excessive and the interrupter must be replaced. (See Phase Assembly Replacement Instructions).

7. After measuring contact tip gap make sure caps have been retightened (Refer to Dismantling).

8. After contactor is completely reassembled reconnect power (Refer to Connections).

Before putting contactor back into service, a general inspection of the contactor should also be made. Manually operate the contactor, check for freedom of movement and general cleanliness.

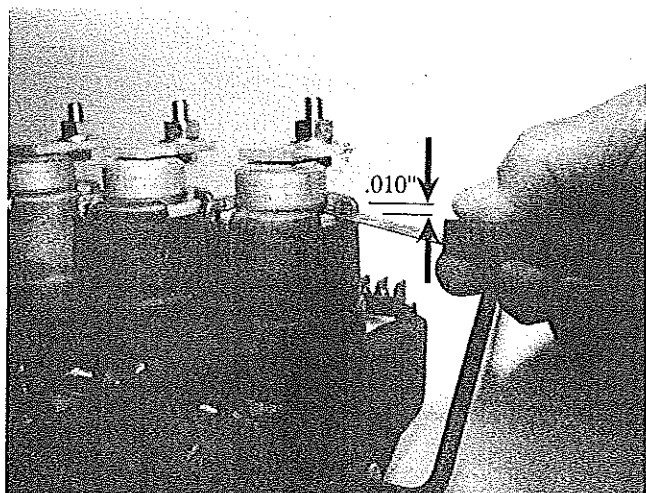

FIGURE 6

VACUUM INTERRUPTER INTEGRITY TEST

A high potential test will determine the dielectric condition and vacuum integrity for each vacuum interrupter.

CAUTION

A HIGH POTENTIAL TEST SHOULD BE PERFORMED ON EACH VACUUM INTERRUPTER IF THERE IS REASON TO SUSPECT VACUUM BOTTLE DAMAGE.

DANGER

EXERCISE CAUTION WHILE PERFORMING HIGH POTENTIAL TEST. HIGH VOLTAGES APPLIED ARE POTENTIALLY HAZARDOUS

The vacuum integrity test should be performed if contactor has been exposed to fault conditions. In addition, it is recommended that a vacuum integrity test be performed once a year as part of regular maintenance.

If contactor has been exposed to fault conditions, as indicated by blown fuses or tripped circuit breaker, the following checks must be made on the vacuum interrupter assemblies.

- a. Physical evidence of stress (distorted, discolored, or cracked bottles).
- b. Contact wear measurement (Refer to Contact Tip Measurement).
- c. Contact resistance.
- d. High Potential Test (Dielectric Test) If contactor is mounted in a controller, remove before performing inspections and tests.

CONTACT RESISTANCE

A contact resistance test can be performed using a micro-ohmmeter. This test determines the condition of contact tip surfaces.

With the contactor closed, the resistance across the terminals should be less than 200 micro-ohms. If higher contact resistance values are measured then the high potential test should be performed.

DANGER

POSSIBILITY OF X-RAY EXPOSURE

PERSONNEL SHOULD BE NO CLOSER THAN 10 FEET AND PREFERABLY BEHIND A METAL BARRIER. TEST TIMES SHOULD BE KEPT TO A MINIMUM. THIS IS A PRECAUTION UNTIL SUCH TIME AS THE POSSIBLE HAZARD IS BETTER UNDERSTOOD AND STANDARDS ARE PUBLISHED.

HIGH POTENTIAL TEST (DIELECTRIC TEST)

The following test should be performed using a 50/60 Hertz test set, where the voltage is continuously variable up to at least 10KV R.M.S. X-radiation at this level is negligible, however, personnel should not be closer than 10 feet to the interrupter under test to avoid high voltage shock hazards. The contactor should be free of dust and other contaminants before conducting this test.

Before Performing high potential test it is recommended you remove contactor from enclosure. The line and load power cables on each phase and control wires 1 and 2 on control terminal boards must be disconnected to avoid any possible feedback to upstream or downstream equipment.

Connect output leads of test set across the interrupter terminals with the contactor in the OPEN position. **Slowly** raise the voltage from zero to 10KV R.M.S. and hold for 15 seconds. During voltage ramping any discharge or test tripping should be ignored unless it becomes impossible to reach 10KV R.M.S. The leakage current should not exceed 5 milliamps during the test. Reverse the test set leads on interrupter terminals and repeat the test. If unit fails test, then phase assembly should be replaced (See Phase Assembly Replacement Instructions).

DISMANTLING (FIGURE 7)

To remove the control module, place contactor on flat surface and depress cover housing with thumb at points "A", unscrew caps "B". With all phase caps loosened the module will be released from the base extrusion. Removal of the control terminal wires will enable the module to be taken to a service bench. (NOTE: the caps may have to be loosened and retightened with a strap wrench to snug fit; **DO NOT OVERTIGHTEN**)

To reassemble the contactor, place the phase assemblies in the base as shown in FIGURE 7 and align magnet plungers "C", with coils in the control module assembly "D" hold the control module level, so that plungers "C" are horizontal and in line with coil holes. Tip the pole assembly approximately 15° and push the lower lip of the control module E into F. Tipping the module downward slightly at arrow G, push the control module to the phase assembly caps and retighten to a snug fit. The control terminal wires, if removed from the module, can be replaced.

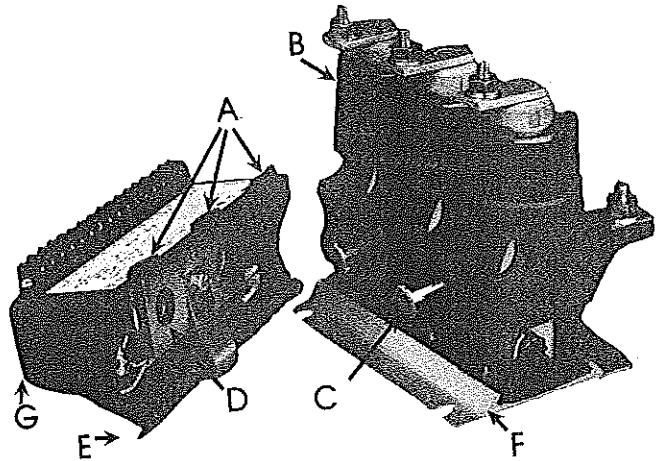
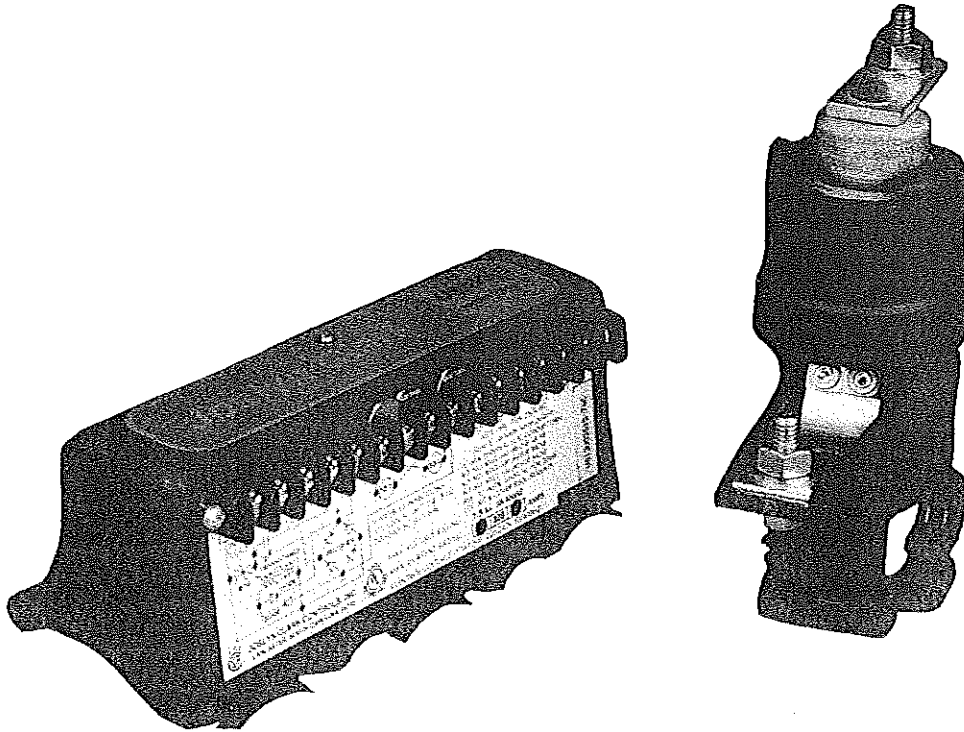

FIGURE 7

PHASE ASSEMBLY REPLACEMENT

The phase assembly simply slides off the main shaft and a new unit slides back on in its place. To remove the phase assembly follow the dismantling procedure detailed above and for reassembly follow this procedure.

PARTS



Contactor Type		160A	320A	600A	1000A
Description	Part#	Quantity	Quantity	Quantity	Quantity
160A Phase Assy		3			
320A Phase Assy			3	6	9
Control Module		1	1	2	3
Line Term Boot		1 (3)*	1(3)*	0(2)*	0 (3)*
Load Term Boot		1 (3)*	1(3)*	0(2)*	0 (3)*

* 1501-3300V. Rating Requirements

NOTE: Double quantities for mechanical interlocked arrangements.

DIMENSIONS

