

EA190 — Crank Interlock Switch

Crank Interlock Switches provide an interlock between the boat davit hand crank and gear box. Specify either left or right hand. Switch cannot be converted in the field.

EA190 — Brake Interlock Switch

The Brake Interlock Switch provides an interlock for braking of the boat davit and is available in either left or right hand models. Please specify by correct part number since these cannot be modified in the field.

EA190 — Trackway Limit Switch

The Trackway Switch limits the up or down travel of the boat davit and, like the other switches, is offered in right or left hand units and normally open or closed contact arrangements. Specify whether left hand or right hand is required and whether normally open or normally closed contacts are required.

EA190

Model Number	Lever Location	Arrangement	Trip Travel
CRANK INTERLOCK SWITCH			
EA190-00055	Left hand	-	20°
EA190-00065	Right hand	-	20°
BRAKE INTERLOCK SWITCH			
EA190-00035	Left hand	-	20°
EA190-00045	Right hand	-	20°
TRACKWAY LIMIT SWITCH			
EA190-00015	Left hand	N.C.	6°
EA190-00025	Right hand	N.C.	6°
EA190-00016	Left hand	N.O.	6°
EA190-00026	Right hand	N.O.	6°

Common Switch Characteristics

SINGLE POLE, SPECIAL NAVY MARINE, SLIDING CONTACTS

Ambient Temperature Range	-50°C min.
Enclosure	Watertight (3 ft. for 2 hrs.) per MIL-STD-108E

Crank Interlock

MIL-C-2212
Navy "A" High Shock
Continuous Current Carrying - 15 amps @ 440 VAC or 230 VDC
Insulation Class B

Brake Interlock

MIL-C-2212, MIL-C-2214
Navy "A" High Shock
Continuous Current Carrying - 15 amps @ 440 VAC or 230 VDC
Insulation Class B

Trackway

MIL-C-2174, MIL-C-2212
Continuous Current Carrying - 20 amps @ 440 VAC or
5 amps @ 230 VDC
Non-Magnetic/Fungistatic Materials
Lever Adjustment - 10° increments thru 360°

See Operating Levers Section

Dimensions and Mounting

EA190

CRANK INTERLOCK SWITCH

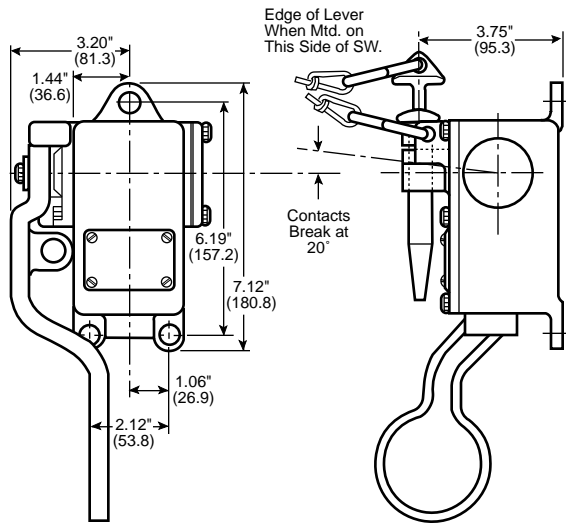

BRAKE INTERLOCK SWITCH

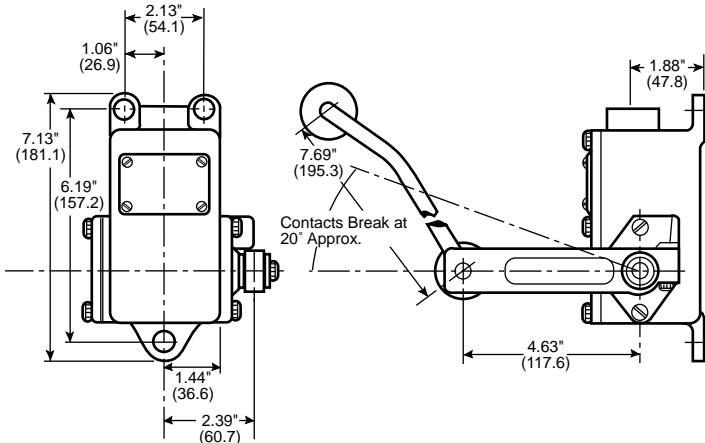

TRACKWAY LIMIT SWITCH

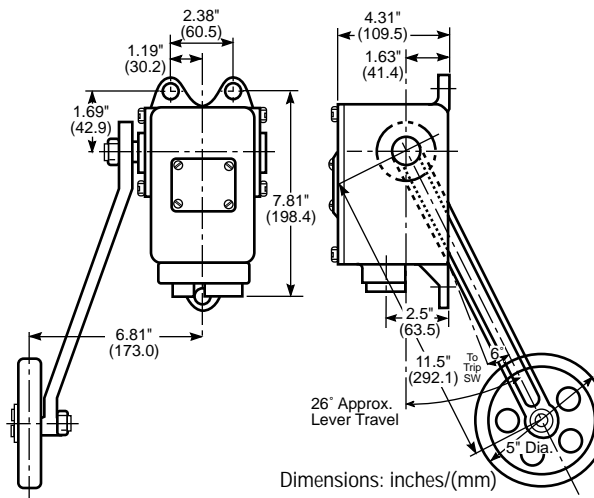

Operational Data Drawing

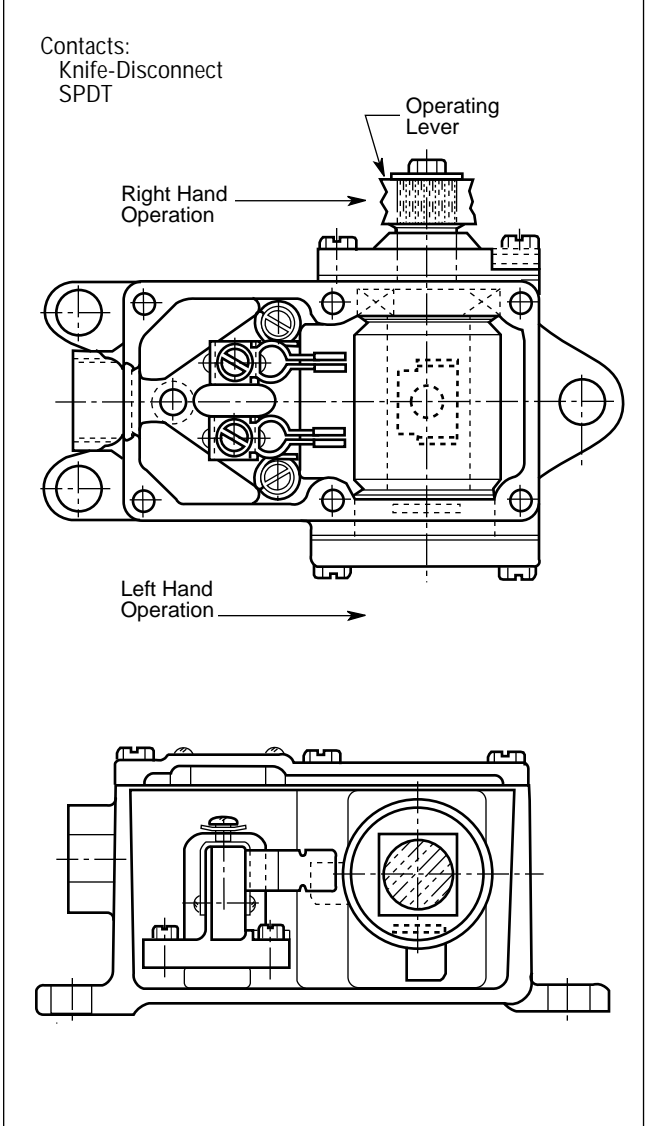

Limit Switches

NAMCO

2013 West Meeting Street • Lancaster, SC 29720
 1-803-286-8491 • FAX: 1-800-678-6263
www.namcocontrols.com

For technical assistance, call 1-800-NAMTECH