

Flat Face  
Round Face

# Dual Position Valve Sensors

DC  
AC

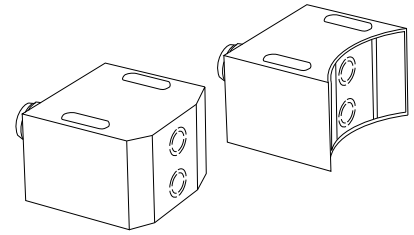

- Senses open and closed valve position in a single-piece compact housing
- Epoxy encapsulated
- Available in AC, DC, and Namur configurations
- 4-pin Euro connector or cable versions available
- Easily mountable
- Compact; approximately one square inch mounting footprint

The new NAMCO Valve Position Proximity Sensor employs a single-piece design to simplify installation. Two inductive proximity sensors are in a single housing. These sensors monitor target disks on the valve actuator, sensing up to four disk combinations which correspond to valve positions. The

sensor is epoxy encapsulated and utilizes surface mount electronics for reliable operation under harsh industrial conditions. Three models are available: one with a standard 10-30 VDC output, one with 80-250 VAC, and the other a Namur-style for hazardous location use.

## 4mm Range Plastic Housing Valve Sensors

Connector Type	Circuit Description	Housing Style	Model Number	Voltage Drop	Maximum Load Current	Short Circuit Protected
<b>4mm SENSING RANGE NAMUR</b>						
2 m Cable	2 W NAMUR	Round Face	ET912-43310	4.5V@ 200mA	200mA	Yes
2 m Cable	2 W NAMUR	Flat Face	ET912-53310	4.5V@ 200mA	200mA	Yes
4-pin euro	2 W NAMUR	Round Face	ET912-43351	4.5V@ 200mA	200mA	Yes
4-pin euro	2 W NAMUR	Flat Face	ET912-53351	4.5V@ 200mA	200mA	Yes
<b>4 mm SENSING RANGE 10 - 30VDC</b>						
2 m Cable	3-W PNP NO	Round Face	ET911-43110	2.5V@ 200mA	200mA	Yes
2 m Cable	3-W NPN NO	Round Face	ET910-43110	2.5V@ 200mA	200mA	Yes
2 m Cable	3-W PNP NO	Flat Face	ET911-53110	2.5V@ 200mA	200mA	Yes
2 m Cable	3-W NPN NO	Flat Face	ET910-53110	2.5V@ 200mA	200mA	Yes
4-pin euro	3-W PNP NO	Round Face	ET911-43151	2.5V@ 200mA	200mA	Yes
4-pin euro	3-W NPN NO	Round Face	ET910-43151	2.5V@ 200mA	200mA	Yes
4-pin euro	3-W PNP NO	Flat Face	ET911-53151	2.5V@ 200mA	200mA	Yes
4-pin euro	3-W NPN NO	Flat Face	ET910-53151	2.5V@ 200mA	200mA	Yes
<b>4mm SENSING RANGE 80 - 250VAC</b>						
2 m Cable	2 W AC NO	Round Face	ET920-43410	11V@ 200mA	200mA	No
2 m Cable	2 W AC NO	Flat Face	ET920-53410	11V@ 200mA	200mA	No
3 pin micro	2 W AC NO	Round Face	ET920-43420	11V@ 200mA	200mA	No
3 pin micro	2 W AC NO	Flat Face	ET920-53420	11V@ 200mA	200mA	No

► Consult factory for normally closed model availability.



Special Application Solutions

## Common Sensor Characteristics

VALVE PROXIMITY SENSORS			
	3-Wire DC	2-Wire AC	NAMUR
Supply Voltage	10-30V DC	80-250V AC	5-25V DC
Voltage Drop	≤ 2.5V @ 200mA	11V @ 200mA	n/a
Max. Load Current @ 25°C	200mA	200mA	2.2mA
Leakage Current	10µA	10µA	n/a
Sensing Range	4mm		
Reverse Polarity Protected	Yes	Yes	n/a
Max. Switching Frequency	180/400Hz	20Hz	400Hz
Ambient Temp. Range	-25°C to 70°C (-13°F to 158°F)		
Short Circuit Protected	Yes	No	n/a

## LED Functions

	3-Wire DC	2-Wire AC	NAMUR
	Yellow	Yellow	Yellow
Power Off	Off	Off	Off
Power On - Load De-energized	Off	Off	Off
Power On - Load Energized	On	On	On

## Circuit Drawings

### EURO CONNECTOR MODELS

3 Wire DC N.O.

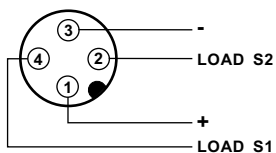

NAMUR

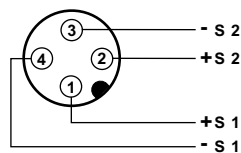

### MICRO CONNECTOR MODEL

2 Wire AC N.O.

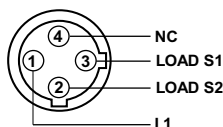

## Dimensional Drawings

DC AC

### ROUND FACE

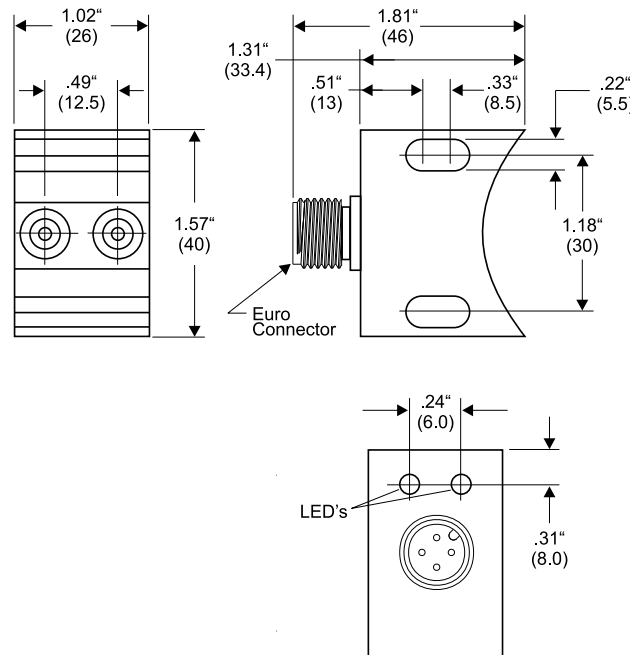

### FLAT FACE

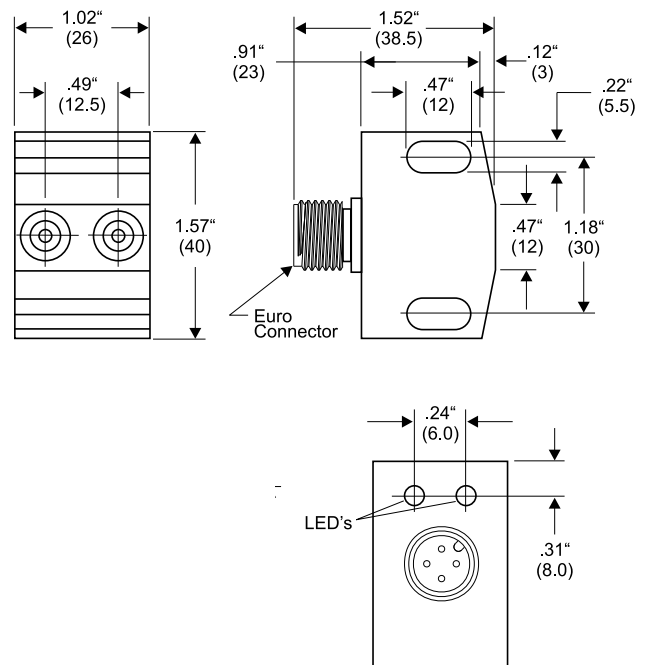

Special Application Solutions

**NAMCO**

2013 West Meeting Street • Lancaster, SC 29720  
1-803-286-8491 • FAX: 1-800-678-6263  
www.namcocontrols.com

For technical assistance, call 1-800-NAMTECH