

Description:

These Namco Cylindicator® proximity sensors are 100% solid-state switches featuring Short Circuit Protection.

The mechanical and electrical operating life of a sensor is largely determined by proper application and installation procedures. Please consult the factory should any questions remain after reading these instructions.

Operating Recommendations:

- Always operate the sensor with a resistive load that will limit the current in the circuit to levels that are within the sensor's specifications. Frequent activation of the sensor's short circuit protection could be an indication that a problem exists between the sensor and the load.
- Devices such as motors and incandescent bulbs should not be directly controlled by a proximity sensor, as their high current typically exceeds the maximum load current rating for the sensor.
- Never install a sensor such that the target or actuator will make actual contact with the sensing face. Damage to the sensor's face can cause a malfunction or failure.
- Do not attempt to modify the sensor by cutting, grinding, filing, etc.
- All sensors are completely epoxy potted, and as such do not have any serviceable parts inside. Do not remove the cover or tamper with the cable or connector.
- The user should refer to NFPA 70B, RECOMMENDED PRACTICE FOR ELECTRICAL EQUIPMENT MAINTENANCE, published by the National Fire Protection Association, for additional information.
- The Short Circuit Protection feature is designed to protect the proximity sensor and not the external circuit.
- Use of a Short Circuit Protected sensor does not eliminate the need for branch circuit fusing.
- Safety first - remove power before correcting short circuit condition.

WARNING:

A SWITCH IN A PROTECTIVE INTERLOCKING CIRCUIT SHOULD BE USED WITH AT LEAST ONE OTHER DEVICE THAT WILL PROVIDE A REDUNDANT PROTECTIVE FUNCTION, AND THE CIRCUIT SHOULD BE SO ARRANGED THAT EITHER DEVICE WILL INTERRUPT THE INTENDED OPERATION OF THE CONTROLLED EQUIPMENT. (PROPOSED NEMA ICS 2-225.95 St'd.)

SERVICING ENERGIZED INDUSTRIAL CONTROL EQUIPMENT CAN BE HAZARDOUS. SEVERE INJURY OR DEATH CAN RESULT FROM ELECTRICAL SHOCK, BURN OR UNINTENDED ACTUATION OF CONTROLLED EQUIPMENT.

RECOMMENDED PRACTICE IS TO DISCONNECT AND LOCK OUT CONTROL EQUIPMENT FROM POWER SOURCES, AND DISCHARGE STORED ENERGY IN CAPACITORS, IF PRESENT. IF IT IS NECESSARY TO WORK IN THE VICINITY OF ENERGIZED EQUIPMENT, ONLY QUALIFIED PERSONNEL SHOULD BE PERMITTED TO PERFORM SUCH WORK, USING ALL APPLICABLE SAFETY PRACTICES AND PROTECTIVE EQUIPMENT.

Short Circuit Protection:

If the sensor's output is shorted, the Short Circuit Protection (SCP) feature will be activated. SCP is designed to protect the sensor's internal circuitry against damage caused by accidental short circuits. SCP is not intended for protection of external control circuits; the use of short-circuit-protected sensors does not eliminate the need for appropriate branch circuit fusing.

The SCP feature of this product is a non-latching-type (self-resetting); the occurrence of a short circuit condition will cause the sensor output to immediately turn off and flash the sensor output indicator ("S1" or "S2") and the "Ready" indicator continuously. The sensor will remain in this state as long as the short circuit is present, and will automatically self-reset within 120msec after the fault is cleared.

LED Functions	Sensor 1		Sensor 2	
	Ready	S1	Ready	S2
Power/Ready	Green	Off	Green	Off
Sensor 1 Targeted	Green	Yellow	Green	Off
Sensor 2 Targeted	Green	Off	Green	Yellow
Sensor 1 SCP Tripped	Flashing		Green	Off
Sensor 2 SCP Tripped	Green	Off	Flashing	

Dimensions (inches)

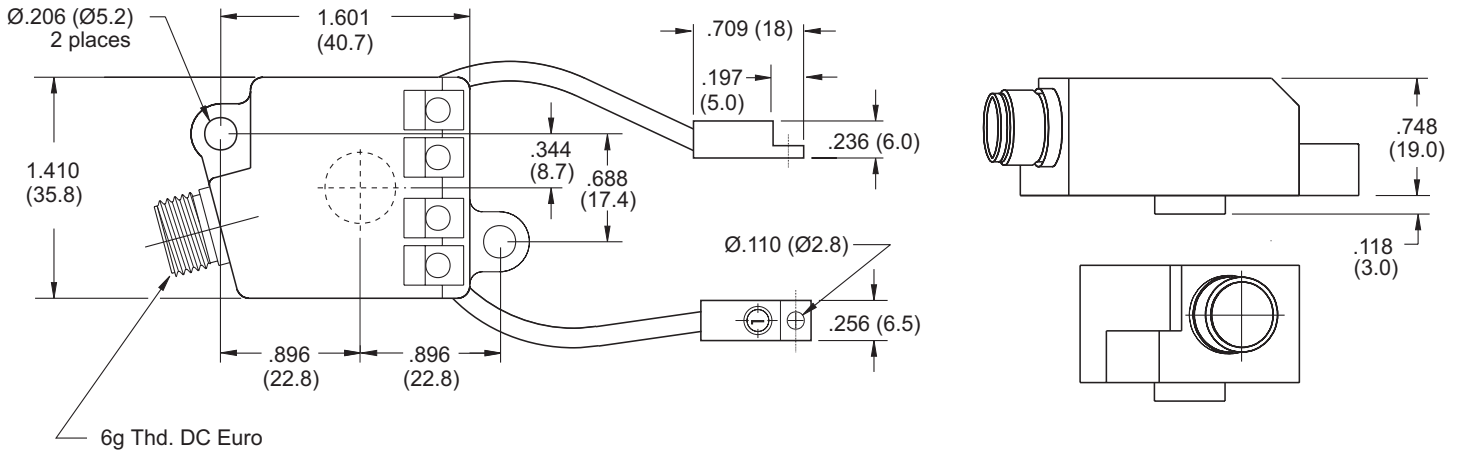

Recommended mounting screw tightening torque:

- 20-25 inch- lbs. for connector/indicator body
- 2-5 inch-lbs. for sensors

Specifications	3-wire DC Sourcing
Supply Voltage	10-30VDC
Sensing Range	2.0mm (.08") ±10%
Temperature Drift (Max.)	±10%
Current Consumption	10mA
Voltage Drop	2.0V @ 100mA
Load Current	200mA Max.
Leakage Current	10µA
Weld Field immune/RF immune	Yes
Short Circuit Protection (SCP)	Yes
Reverse Polarity Protection	Yes
Response Time (On)	30ms
Response Time (Off)	1ms
Switching Frequency	16Hz
Hysteresis	3-10%
Connector	4-pin single-key euro
Operating Temperature Range	-25°C to +70°C

Sensor Mounting Details

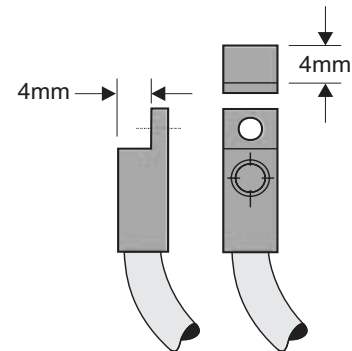

Wiring Diagrams

