

NAMUR Sensors

Hazardous Location Sensor Systems

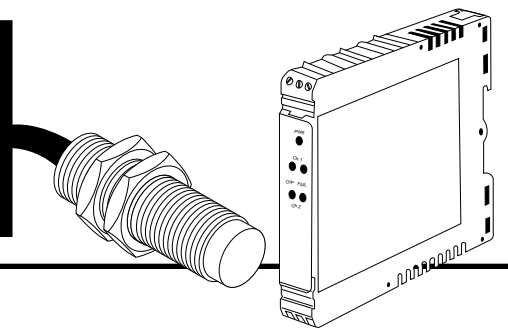

NAMUR refers to the standards committee of measurement and control of the chemical industry of Europe. Namco sensors comply with DIN 19234 and therefore are compatible with the NAMUR requirements.

NAMUR sensors are typically used for hazardous location sensing in areas

that require extremely compact sensors. Namur Sensors are not stand-alone sensors unless your control system input is capable of determining current change. Unlike most other sensors, the Namur Sensor uses very low voltage as a source and changes the current passed through as a function of how close the

target is to the sensing coil. Namur sensors are used with either stand-alone amplifiers or Namur specific PLC input cards. When used in a hazardous location, an appropriate barrier is required.

Special Application Solutions

Connector Type	Circuit Description	Housing Material	Housing Length	Shielded Model No.	Unshielded Model No.	Sensing Range		Maximum Load Current	Maximum Switching Frequency		Short Circuit Protected	
						Shielded	Unshielded		Shielded	Unshielded		
6.5mm Diameter NAMUR 5-25 VDC Smooth												
6.6' Cable	Analog	Metal	30mm	ET112-00310	—	1mm	—	N/A	1KHz	—	N/A	
8mm Diameter NAMUR 5-25 VDC												
6.6' Cable	Analog	Metal	30mm	ET112-10310	—	1mm	—	N/A	1KHz	—	N/A	
12mm Diameter NAMUR 5-25 VDC												
6.6' Cable	Analog	Metal	30mm	ET112-20310	ET112-21310	2mm	4mm	N/A	800Hz	400Hz	N/A	
6.6' Cable	Analog	Plastic	30mm	ET212-20310	ET212-21310	2mm	4mm	N/A	800Hz	400Hz	N/A	
18mm Diameter NAMUR 5-25 VDC												
6.6' Cable	Analog	Metal	30mm	ET112-30310	ET112-31310	5mm	8mm	N/A	500Hz	200Hz	N/A	
6.6' Cable	Analog	Plastic	30mm	ET212-30310	ET212-31310	5mm	8mm	N/A	500Hz	200Hz	N/A	
30mm Diameter NAMUR 5-25 VDC												
6.6' Cable	Analog	Metal	40mm (Sh) 42mm (UnSh)	ET112-40310	ET112-41310	10mm	15mm	N/A	300Hz	250Hz	N/A	
6.6' Cable	Analog	Plastic	40mm	ET212-40310	ET212-41310	10mm	15mm	N/A	300Hz	250Hz	N/A	
Small Rectangular NAMUR 5-25 VDC												
6.6' Cable	Analog	Plastic	12x26x40mm	ET912-10310	ET912-11310	2mm	4mm	N/A	800Hz	400Hz	N/A	

Please consult factory for other versions.



Common Sensor Characteristics

NAMUR DC SENSORS	
Shielded Sensing Range	6.5mm: 1mm 8mm: 1mm 12mm: 2mm 18mm: 5mm 30mm: 10mm Sm. Rec.: 2mm
Unshielded Sensing Range	8mm: 2mm 12mm: 4mm 18mm: 8mm 30mm: 15mm Sm. Rec.: 4mm
Shielded Standard Target (mm) (mild steel)	6.5mm: 8x8x1 8mm: 8x8x1 12mm: 12x12x1 18mm: 18x18x1 30mm: 30x30x1 Sm. Rec.: 12x12x1
Unshielded Standard Target (mm) (mild steel)	8mm: 8x8x1 12mm: 12x12x1 18mm: 24x24x1 30mm: 45x45x1 Sm. Rec.: 16x16x1
Repeatability	2%
Hysteresis	3-8% (typ.); 15% (max.)
Temperature Drift (Max.)	±15%
Ambient Temperature Range	-13°F to +158°F
Current Consumption	N/A
NEMA Rating	1, 3, 4, 6, 13
LED Indicator	N/A
Metal Housings	Chromed Brass
Plastic Housings	Ultradur®
Shipping Weight	6.5mm: 8 oz. 8mm: 8 oz. 12mm: 8 oz. 18mm: 8 oz. 30mm: 10 oz. 34mm: 11 oz. Flat Pack: 5 oz. (Add 5 oz. for Cable model)

Circuit Drawings

SENSOR WIRING DIAGRAM

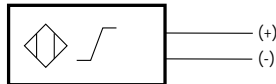

Dimensional Drawings

NAMUR

6.5mm DIAMETER SENSOR

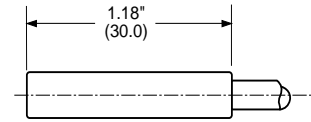

8mm DIAMETER SENSOR

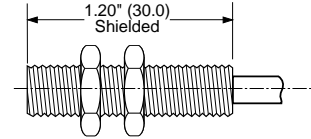

12mm DIAMETER SENSOR

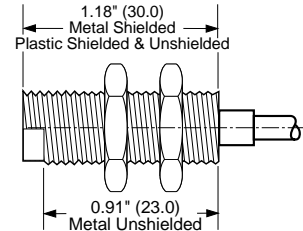

18mm DIAMETER SENSOR

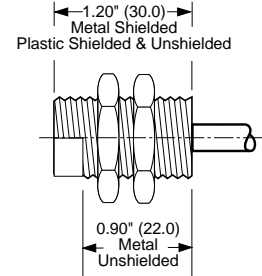

30mm DIAMETER SENSOR

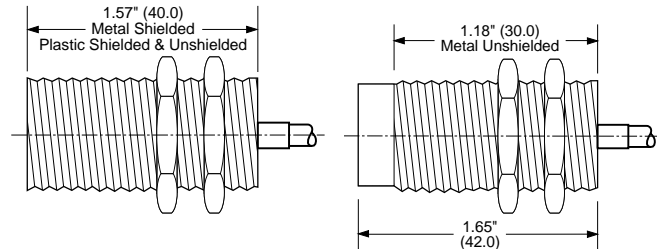

Small Rectangular SENSOR

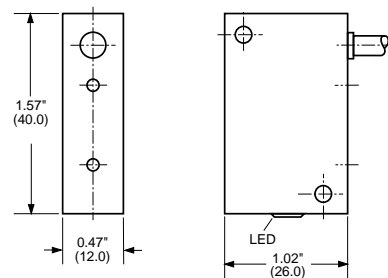

Special Application Solutions

NAMCO

2013 West Meeting Street • Lancaster, SC 29720
1-803-286-8491 • FAX: 1-800-678-6263
www.namcocontrols.com

For technical assistance, call 1-800-NAMTECH

**Intrinsically
Safe**

Hazardous Location Sensor Systems

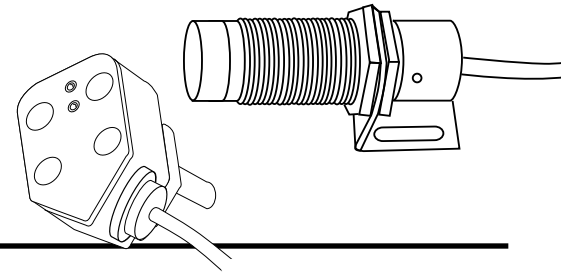

For use in:

Class I - Groups A, B, C, & D
Class II - Groups E, F, & G

The EE931 Hazardous Location sensor system is excellent for sensing of position in paint spray booths, belt slip on conveyors, or anywhere that explosion proof switches are normally used. Since the EE931 system is intrinsically safe, no special housings are required to contain any potential flame. Intrinsic Safety is obtained by design of the product such that extremely limited energy is available in the hazardous location. For this reason, these Namco sensors must only be used with the Namco control module. It is possible, however, to use the Namco control module with either the Namco sensors listed in this section or a standard limit switch. (Limit switches must be of the gold contact type due to the low current and voltage supplied by the control module.)

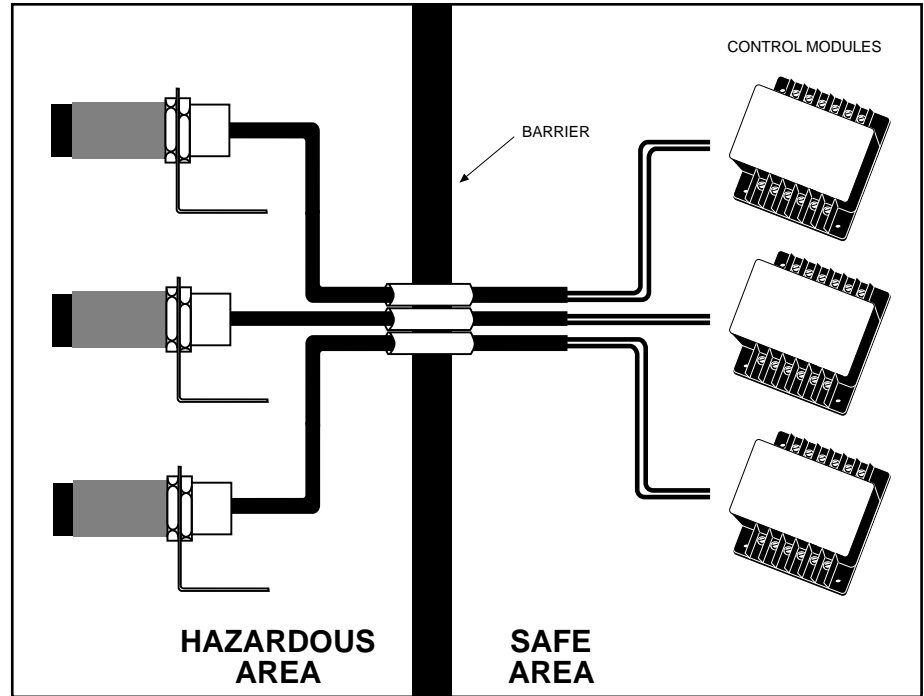

An intrinsically safe proximity sensor system consists of a sensor, which is mounted in the hazardous area, and a control module, which is mounted in the safe area.

Special Application Solutions

Sensors

Namco offers a variety of intrinsically safe sensors for use in Class I, Groups A, B, C, and D and Class II, Groups E, F, and G hazardous locations. These EE931-series sensors must be used ONLY in conjunction with Namco's EE931-series control modules. The hazardous location sensors are completely encapsulated and contain a transistor oscillator circuit. Variations in oscillator amplitude caused

by metallic objects passing in front of the sensor face produce activation of the control module output.

Twenty feet of 18AWG oil resistant cable is provided with tubular sensors, although up to 1000 feet can be obtained for applications where the hazardous area is a considerable distance away from the safe area control panel. Sensors providing up to one inch of sensing range are available.

Cylindicator® sensor versions are provided with 50 feet of cable. For longer cable lengths, consult factory.



Cylindicator® Sensors

Model No.	Probe Length
EE931-30101	0.950
EE931-30401	1.025
EE931-31301	1.250
EE931-38701	2.062
EE931-37801	2.875
EE931-39001	3.775

Tubular Sensors (See "Sensing Range" opposite page)

Model No.	Sensing Range		"C" Mtg. Clear.	Thread	Cable (20')
	"A" Sensing Field	"B" Side			
EE931-56200	0.20" (5.0)	0.25" (6.3)	0.40" (10.1)	3/4"-20	2 Cond. 18 AWG SVO
EE931-76500	0.37" (9.5)	0.25" (6.3)	0.57" (14.6)	M30 x 1.5	2 Cond. 18 AWG SVO
EE931-75100	1.00" (25.4)	0.50" (12.7)	2.50" (63.5)	M30 x 1.5	2 Cond. 18 AWG SVO

Dimensional Drawings

90° ROTATABLE CYLINDRATOR® SENSOR

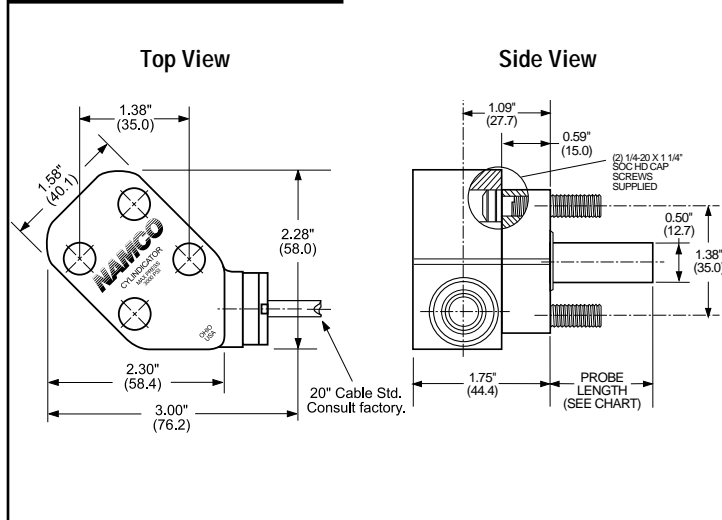

Sensor Mounting

Sensors may be installed with mounting bracket furnished in any position provided the sensor face is kept free of electrically conductive material. See below for maximum sensing range and pattern of minimum mounting distances from other conductive materials for the EE931-series sensors.

See the Cylindator section in this book for application information on Cylindator sensors.

Factors influencing sensing range are temperature, target size, target material, and speed. For best all-around performance, use "slide-by" actuation as opposed to "head-on" actuation. Target should present as much surface area to the sensor face as practical. Sensing of non-ferrous metals may reduce sensing range by as much as 50%, depending on the type of material. Since the sensing range of each sensor is fixed, no control module adjustment is required. The target should be placed as close to the sensor face as possible. Namco recommends setting the target at one-half the "maximum" sensing range or closer for best system operation.

Sensing Range

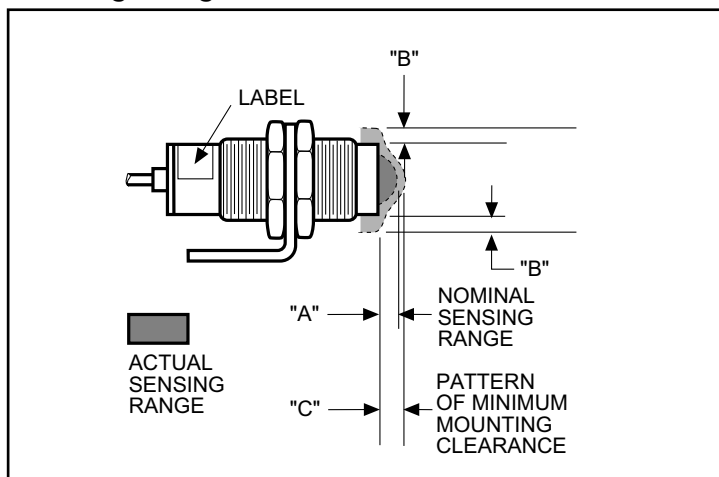

Dimensional Drawings

TUBULAR SENSOR – 3/4-20 THREAD 17mm SMOOTH BARREL

Model No.
EE931-56200

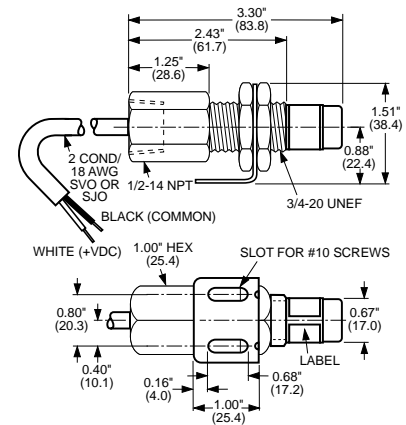

TUBULAR SENSOR – M 30x1.5 FULL THREAD

Model No.
EE931-76500

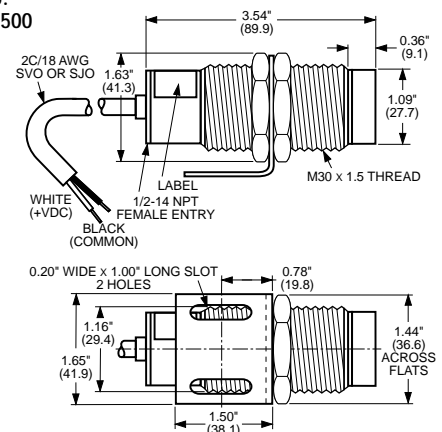

TUBULAR SENSOR – M 30x 1.5 THREAD 1" SMOOTH BARREL

Model No.
EE931-75100

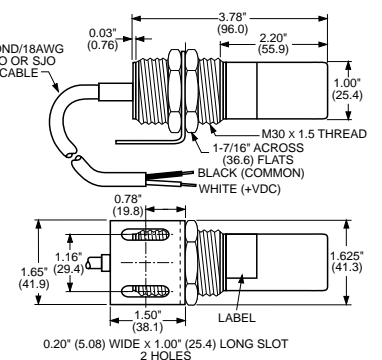

Continued on
next page. →

NAMCO

2013 West Meeting Street • Lancaster, SC 29720
1-803-286-8491 • FAX: 1-800-678-6263
www.namcocontrols.com

For technical assistance, call 1-800-NAMTECH

Intrinsically
Safe

Hazardous Location Sensor Systems

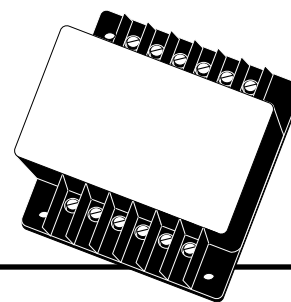

Control Modules

The EE931-series control modules are designed to be mounted in the safe area. These modules provide limited energy to Namco's line of hazardous location sensors described on the previous pages. The control modules are housed in high impact Lexan® enclosures and are equipped with eight screw terminals (#8 stud size) for ease of installation. The EE931-02103 module provides an electro-mechanical relay output (One Form C), while the EE931-02303 unit has a photo-darlington (open collector) output for higher speed requirements. The outputs become energized when a metallic target is present in front of the associated sensor.

Control Module Mounting:

The EE931-series control module **should be panel mounted in the safe area** where it will be protected from physical damage, dirt, and vibration. The location should be established within the limits of the sensor cable. The unit can be mounted vertically or horizontally using two No. 8 screws. When mounting with only two screws, **it is imperative to use the two mounting holes provided with brass eyelet inserts**. This method provides an additional ground path for the electronic circuit contained in the module. The ambient temperature range should be from -40°F to +158°F. The physical construction of the control module housing insures a separation of at least two inches between intrinsically safe terminals (5 and 6) and non-intrinsically safe terminals (7 thru 12).

It is important when installing the sensor cable to the control unit terminals (5 and 6) to maintain this minimum spacing of two inches. A separate wiring duct is required to insure that the intrinsically safe sensor cable does not become intermingled with non-intrinsically safe wiring due to vibration. A separate conductor **MUST** be wired from Terminal 9 to earth ground to insure intrinsic safety of the system. Terminal 8 is for the neutral side of AC line. Terminal 7 is hot side of AC line and **MUST** be wired accordingly or intrinsic safety is voided.

Namco advises that the Instrument Society of America Specification RP12.6, which gives the recommended practice for installation of intrinsically safe systems, be followed when using the EE931-series control modules and sensors.

Dimensional Drawing

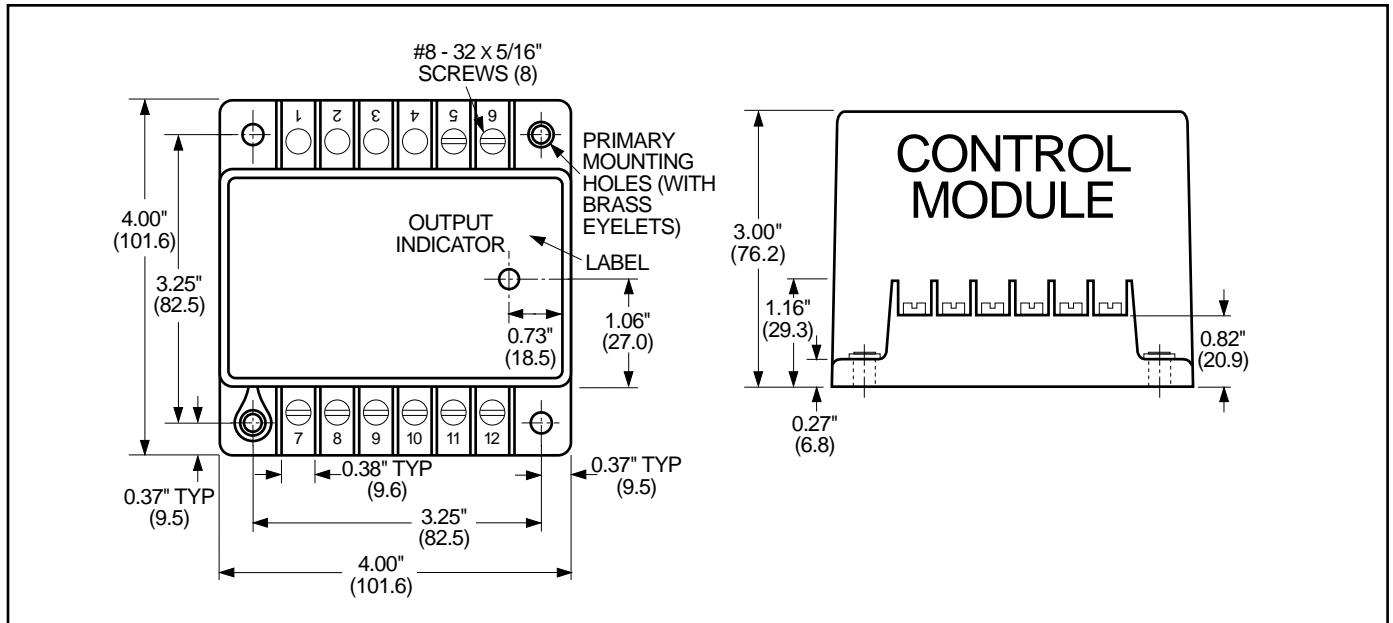

Circuit Drawings

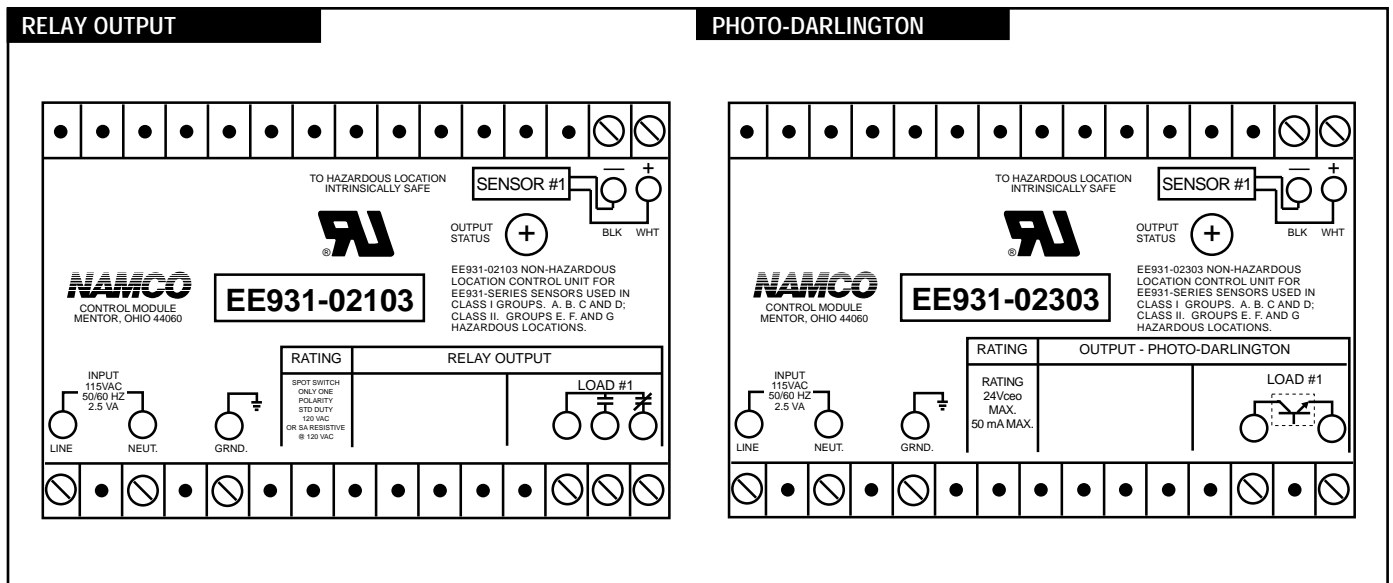

Special Application Solutions

Common Control Module Characteristics

INTRINSICALLY SAFE CONTROL MODULE		
	EE931-02103	EE931-02303
Output	Electro-Mechanical SPDT Relay Rated 5A Resist. One form C	Photo-Darlington 50mA max. @ 24 VAC Open Collector
Speed (Hz)	3	1400
Supply Voltage	120 VAC	
Sensor Input	Namco EE931-Series only	
Ambient Temperature	-40°F to +158°F	
Case Material	Lexan	

NAMCO

2013 West Meeting Street • Lancaster, SC 29720
1-803-286-8491 • FAX: 1-800-678-6263
www.namcocontrols.com

For technical assistance, call 1-800-NAMTECH