

- Underspeed/Overspeed
- Underspeed Only
- Zero Speed

Motion Switch

Namco Controls EE891 Series Motion Switch is a digital system. It compares the time between input pulses with an adjustable reference time base.

The Motion Switch can be used in any of four modes. It may be used for overspeed or underspeed monitoring of rotating equipment with either manual reset or automatic reset. These functions are easily programmed into the unit via external jumper connections.

This series includes models for underspeed detection only as well as zero-speed unit. A choice of outputs is also available.

Series EE891 Motion Switches will accept a wide range of input signals including a simple contact closure. Used in conjunction with our EE510/ET series self-contained DC proximity switches, they offer a high reliability system.

The switch point (or trip frequency) is adjustable through the top of the enclosure. A screwdriver is required to set the trip point. A 15-turn potentiometer with a slip clutch at both ends prevents accidental damage due to excessive rotation.

The unit comes in a tough Lexan* enclosure to protect it from accidental damage. The unit also features plug-in convenience for easy installation or replacement.

**Lexan is a General Electric Product*

Zero Speed Switch

The EE891-32103 Zero Speed Switch is designed to accept either a sinking or sourcing input. The output function can be reversed, relay normally

de-energized or normally energized, with the selector switch located on top of the module. An internal regulated power supply is provided to supply power to self-contained Proximity Switches.

Operating Principles: Standard Motion Switches

Input Signal

- Ground based positive
- Pulse rate to 1KHz with 300 microsecond minimum pulse width. Contains input bounce filter (up to 375 microseconds) for contact closure inputs.
- Internal switch for selecting NPN (sinking) or PNP (sourcing) inputs is accessible through a hole in the top of the module.

Underspeed

Underspeed operation is programmed in the unit by connecting a jumper between pin 3 and pin 4 of the terminal socket. The unit will now drop out if the input pulse rate should fall below the internal reference rate (variable through top of unit by screwdriver adjustment of 15-turn potentiometer).

Overspeed

Overspeed operation is programmed in the unit by connecting a jumper between pin 2 and pin 4 of the terminal socket. The unit will now drop out if the input rate rises above the internal reference rate (variable through top of unit by screwdriver adjustment of 15-turn potentiometer).

Automatic Reset

The output (once de-energized) will remain off until a reset button is closed momentarily. However, if your application requires an automatic reset function, this may be accomplished by connecting a jumper between the manual reset pins instead of a normally open switch.

Input

The Motion Switch is only as reliable as the input information. Therefore, it is extremely important that a good, reliable signal be made available. This can either be from a proximity switch or a contact closure. For reliable operation, the frequency of the target signal should be determined through use of an oscilloscope or tachometer. This frequency can then be applied to the input terminal of the motion switch. We recommend that a signal generator be used for this purpose. (Note: the signal generator should produce a positive only square wave. Any other wave form may damage the unit.)

The adjust potentiometer is then set to the proper "pick-up" point. We recommend that the values chosen for this frequency be approximately 5% above or below the normal "run" speed to allow for normal variations in the target speed. This is a minimum value. Please follow the set-up procedure provided with the particular type of switch used in your application.

NOTE: The EE891-32103 zero speed control module provides for an adjustable OFF delay when either the ON or OFF mode is selected. The OFF delay is retriggerable; therefore, the timing function starts at the beginning of each input pulse. (See Time Delay Chart.)

Operating Principles: Zero Speed Switches

Like the Motion Switch, the Zero Speed Switch accepts either a contact closure, proximity, or photoelectric sensor input. This control module is based on time from the last input to the next as the equipment being monitored slows down.

When the pulse rate disappears for a time exceeding the set point, the output of the zero speed module will change. (The zero speed unit will not be "confused" if the input remains activated due to the target remaining in front of the sensor.)

Typical Applications

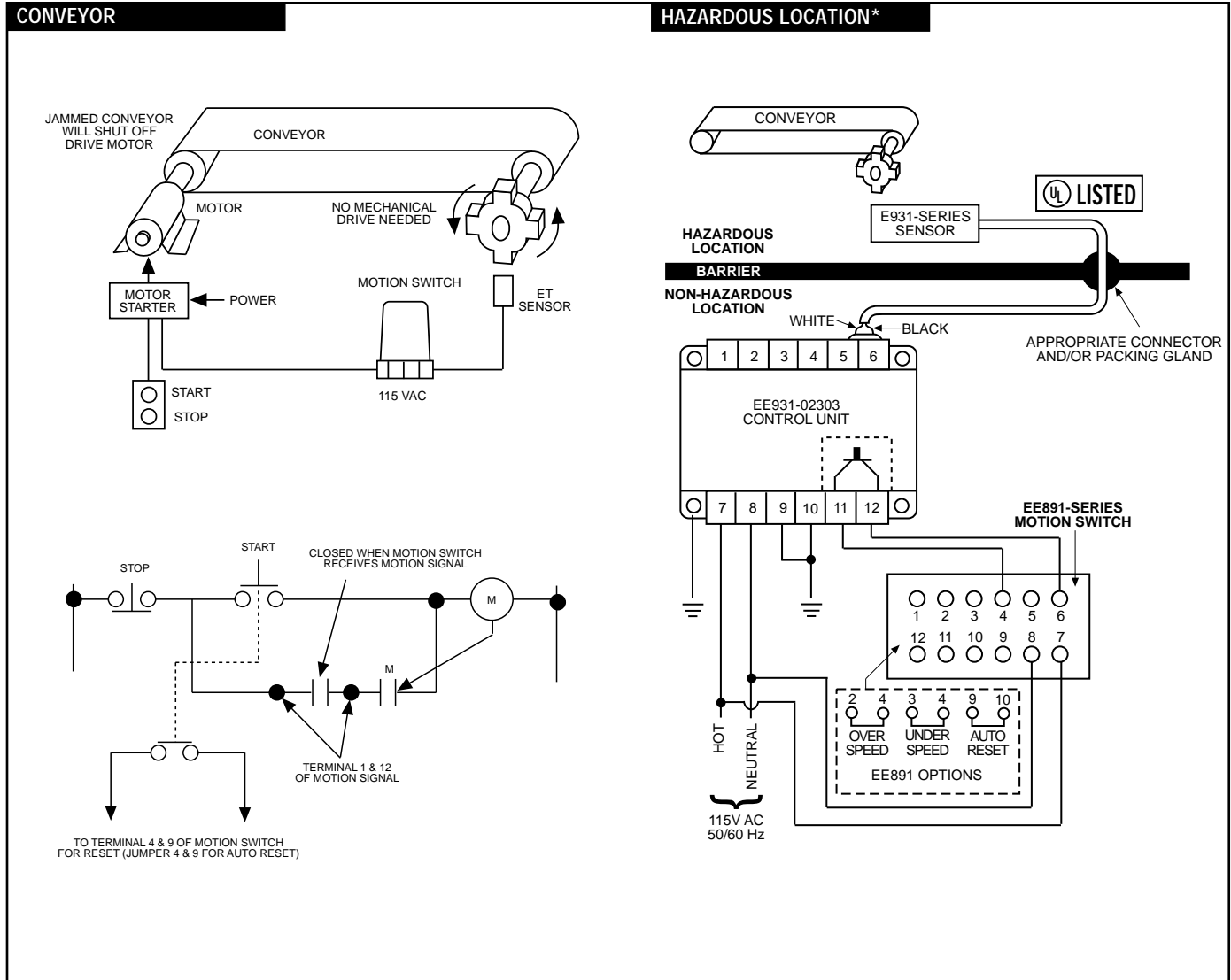

* See Hazardous Location section for more information on Series EE931 products.

Time Delay Chart

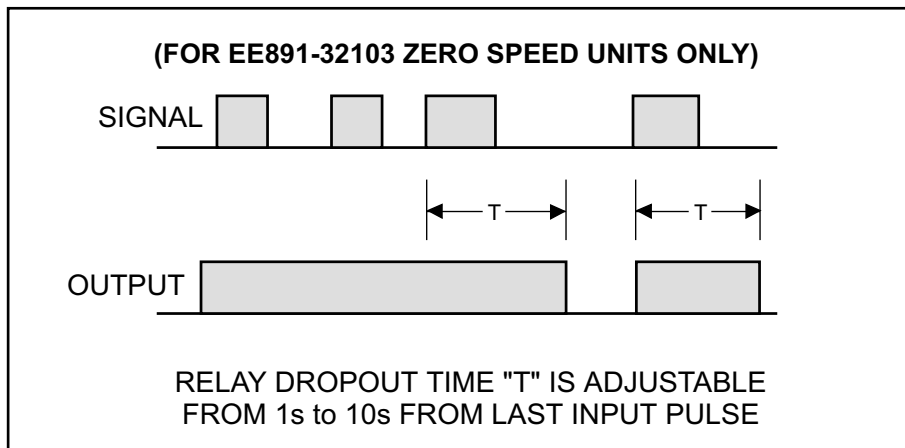

Special Application Solutions



2013 West Meeting Street • Lancaster, SC 29720
 1-803-286-8491 • FAX: 1-800-678-6263
 www.namcocontrols.com

For technical assistance, call 1-800-NAMTECH

Motion Detection Systems

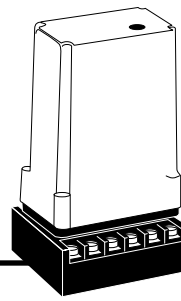

Motion Detection Systems consist of these motion detection modules coupled with a DC proximity sensor. Either the EE510 series or any DC ET-series sensor is compatible. EE931 sensors may also be employed for hazardous location requirements.

Motion Detection Modules

Output	Speed Adjustment Range				UL Listed
	3 to 60 Pulses Per Minute Model No.	24 to 480 Pulses Per Minute Model No.	384 to 7680 Pulses Per Minute Model No.	See Time Delay Chart Model No.	
Motion Switch					
Electromechanical Relay 1 Set Form C 5A-115 VAC Resistive	EE891-02103*	EE891-12103*	EE891-22103*	—	✓
Open Collector 20 ma. sink V ext. max. 40 volts	EE891-02303*	EE891-12303*	EE891-22303*	—	✓
Reed Relay 1 NO, 1 NC, 12VA or 10 watts	EE891-02403*	EE891-12403*	EE891-22403*	—	✓
Underspeed Only Switch					
Electromechanical Relay 1 Set Form C 5A-115 VAC Resistive	EE891-02113	EE891-12113	EE891-22113	—	
Zero Speed Switch					
Electromechanical Relay 2 Form C 5A-115 VAC Resistive	—	—	—	EE891-32103	

*UL Listed.

Order numbers shown are for 120 VAC units.

For intrinsically safe applications, use any EE981 sensor.

Specifications

MOTION DETECTION SYSTEMS		
	MOTION SWITCH	ZERO SPEED
Input	120VAC, 50/60Hz or 230 VAC	120 VAC, 50/60Hz
Electromechanical Relay	1 Set Form C 5A Resistive @ 120 VAC	DPDT 5A Resistive @ 120 VAC
Reed Relay	1 NO - 1 NC 10 W or 12 VA	N/A
Transistor	Vext. 40 VDC max. Sinking, 10 mA	N/A
Solid State Relay	.050 Amps min. to 1.5 Amps max. 240 VAC max.	
DC Power Supply	24VDC, 50 mA max. for sinking (NPN) or sourcing (PNP) Input***	
Drop-Out Time	N/A	1-10 Sec. Adjustable
Hysteresis	5%	N/A
Latch	Yes	N/A
Mode of Operation	Overspeed or Underspeed programmed	N/A
Trip Point Adjust	Yes	N/A
Response Time	<10ms: electromechanical <2ms: reed relay	N/A

**The use of an external suppressor network on relay output models is recommended to prolong contact life.

*** Early models may have 12 VDC supply.

Time Delay Chart

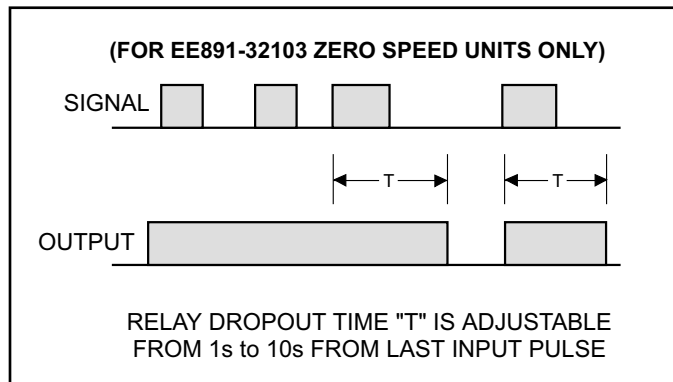

Compatible Sensors (DC versions only)

EE510 Series
 ET Series
 EE931 Series (for Hazardous Locations)

Dimensional Drawings Motion Detection

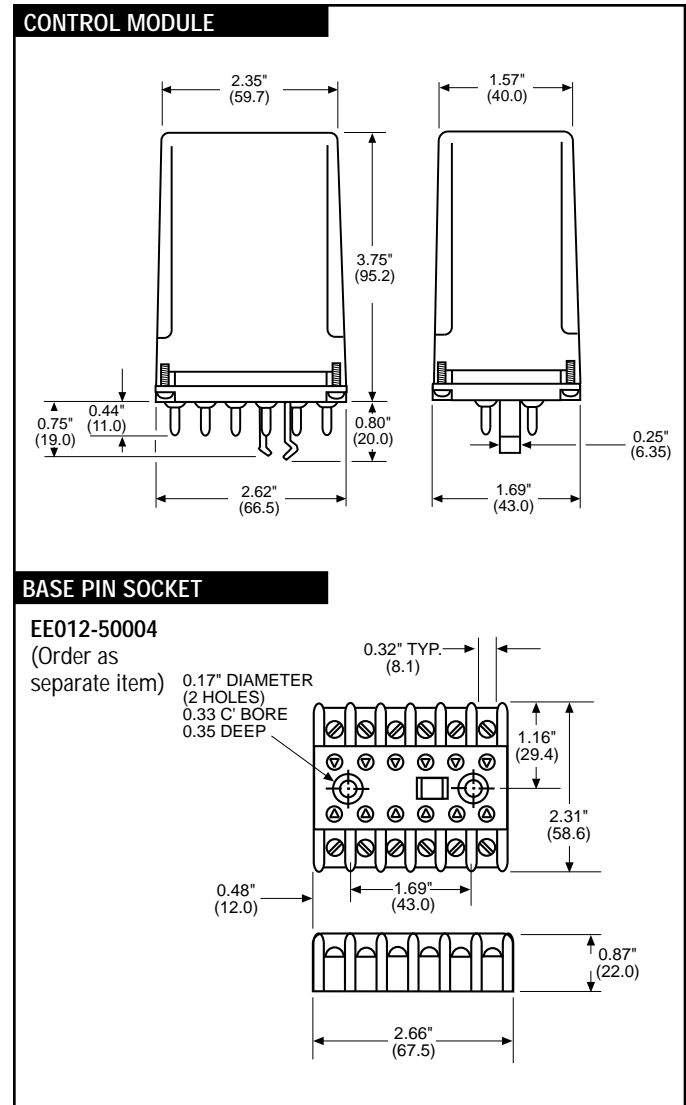

Motion Detection Systems

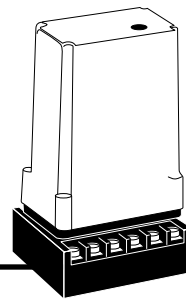

Circuit Drawings

**UNDERSPEED ONLY SWITCH,
ELECTROMECHANICAL RELAY**

Model Nos.
EE891-02113
EE891-12113
EE891-22113

**RELAY OUTPUT 1 FORM "C"
5 AMPS RESISTIVE @ 120V AC**

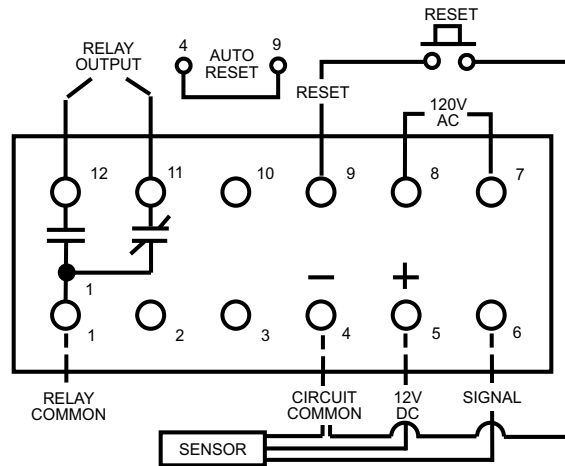

**ZERO SPEED SWITCH,
ELECTROMECHANICAL RELAY
SOLID STATE RELAY**

Model Nos.
EE891-32103

**RELAY OUTPUT: 2 FORM "C" 5 AMP RESISTIVE
@ 120V AC**

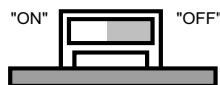
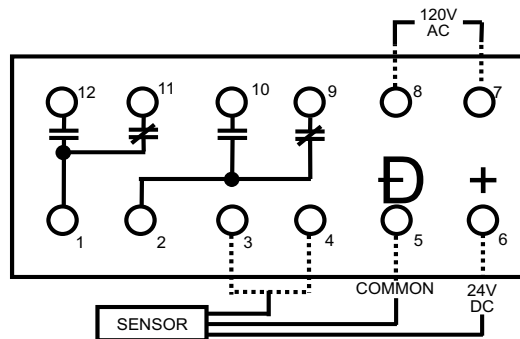

INTERNAL SWITCH
FOR NORMALLY "ON" OR NORMALLY "OFF"
RELAY OPERATION

**MOTION SWITCH,
ELECTROMECHANICAL RELAY**

Model Nos.
EE891-02103
EE891-12103
EE891-22103

**RELAY OUTPUT 1 FORM "C"
5 AMP MAX. RESISTIVE @ 120V AC**

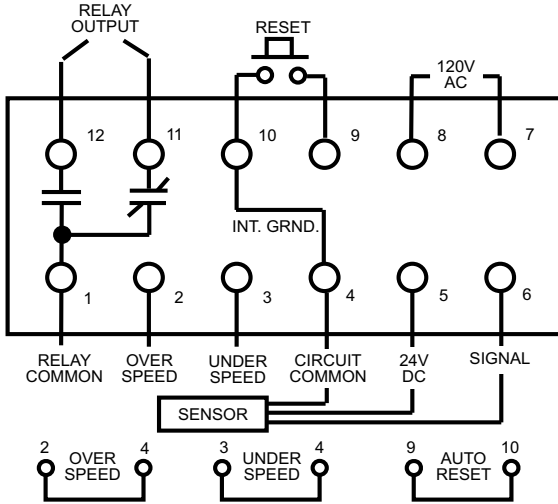

**MOTION SWITCH,
OPEN COLLECTOR**

Model Nos.
EE891-02303
EE891-12303
EE891-22303

V EXT = 40V DC 20 ma MAX.

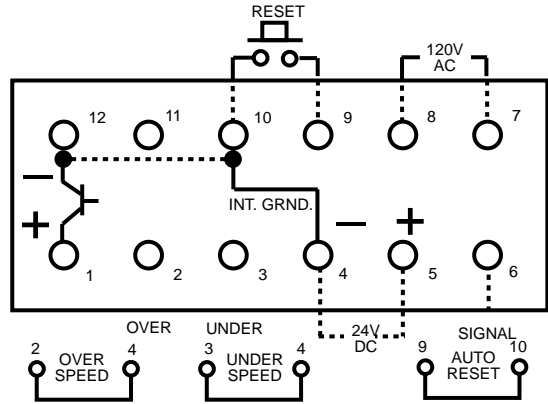

**MOTION SWITCH,
REED RELAY**

Model Nos.
EE891-02403
EE891-12403
EE891-22403

**RELAY OUTPUT
FORM "A" FORM "B"
12 va 120V OR
10 WATT MAX., 500 ma MAX., 120V MAX**

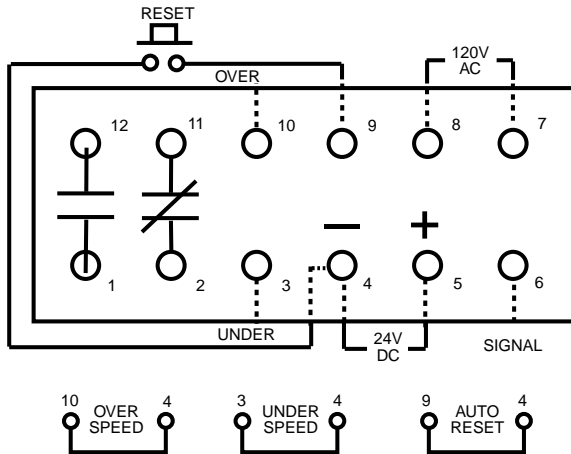

NOTE: Early models may have 12VDC supply.

Special Application Solutions



2013 West Meeting Street • Lancaster, SC 29720
1-803-286-8491 • FAX: 1-800-678-6263
www.namcocontrols.com

For technical assistance, call 1-800-NAMTECH