

Fiber Optic Cables

Photoelectric Sensors Accessories

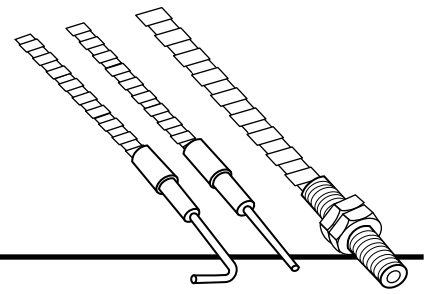

Photoelectric Sensors

- Choice of Sensor Head
- Glass
- PVC or Stainless Steel Jacket
- Sealed Construction
- 3 or 6-Foot Lengths, Standard

The addition of fiber optic cables greatly increases the flexibility of Namco's photoelectric sensors. These cables are used for EP140 and EP240 Series Switches.

Fiber optic cables transmit light from a control unit to an object and then return the reflected light back to the control unit producing an electrical signal. Because of their small size, fiber optic cables may be installed in areas that were inaccessible with other types of sensors. They are very flexible, vibration proof, submersible, and may be used in high temperature areas. Small part detection or counting is accomplished easily to replace unreliable methods such as weighing.

Special applications are easier to accomplish by specifying different tips rather than an entirely new photoelectric control.

Design Features

Optical glass fibers are encased in either a PVC jacket or, for added protection, a flexible armored stainless steel jacket to resist cuts or abrasion. The tips are constructed from stainless steel, brass, or aluminum for long life. The cables are sealed and may be used in "wash down" or submerged applications. Standard lengths are 3 feet and 6 feet. Consult factory for other lengths.

Jacketed Cables

Sensor Head	Bundle Diameter	PVC		Stainless Steel		Approx. Range	
		3' Cable Model No.	6' Cable Model No.	3' Cable Model No.	6' Cable Model No.	Sensitivity Adjustment	
						Minimum	Maximum
SINGLE CABLES							
Hypo Tip	.062	EP181-11020	EP181-11021	EP181-12020	EP181-12021	0.62"	3.00"
Hypo Tip 90°	.062	EP181-11030	EP181-11031	EP181-12030	EP181-12031	0.62"	3.00"
Hypo Tip Bendable	.062	EP181-11120	EP181-11121	EP181-12120	EP181-12121	0.62"	3.00"
Flair Tip Narrow	.062	EP181-11050	EP181-11051	EP181-12050	EP181-12051	0.75"	3.50"
Tight 90° Tip	.094	EP181-11060	EP181-11061	EP181-12060	EP181-12061	4.00"	13.00"
Plain Tip	.125	EP181-11000	EP181-11001	EP181-12000	EP181-12001	5.00"	18.00"
Threaded Tip	.125	EP181-11010	EP181-11011	EP181-12010	EP181-12011	5.00"	18.00"
Flair Tip Wide	.125	EP181-11040	EP181-11041	EP181-12040	EP181-12041	3.25"	13.50"
Plain 90° Tip	.125	EP181-11080	EP181-11081	EP181-12080	EP181-12081	5.00"	18.00"
BIFURCATED CABLES							
Hypo Tip	.062	EP181-21020	EP181-21021	EP181-22020	EP181-22021	0.03"	0.53"
Hypo Tip 90°	.062	EP181-21030	EP181-21031	EP181-22030	EP181-22031	0.03"	0.53"
Hypo Tip Bendable	.062	EP181-21120	EP181-21121	EP181-22120	EP181-22121	0.03"	0.53"
Flair Tip Narrow	.062	EP181-21050	EP181-21051	EP181-22050	EP181-22051	0.00"	0.25"
Tight 90° Tip	.094	EP181-21060	EP181-21061	EP181-22060	EP181-22061	0.28"	1.12"
Plain Tip	.125	EP181-21000	EP181-21001	EP181-22000	EP181-22001	0.38"	1.50"
Threaded Tip	.125	EP181-21010	EP181-21011	EP181-22010	EP181-22011	0.38"	1.50"
Flair Tip Wide	.125	EP181-21040	EP181-21041	EP181-22040	EP181-22041	0.28"	1.12"
Plain 90° Tip	.125	EP181-21080	EP181-21081	EP181-22080	EP181-22081	0.38"	1.50"

NOTE:

	<u>PVC</u>	<u>Stainless Steel</u>
Sheathing O.D.	0.238"	0.234"
Minimum Bend Radius:	0.595"	0.585"
Temperature Range:	-40°F to +235°F	-40°F to +525°F

Cable Types

SINGLE CABLE (for Thru-Beam Sensing)

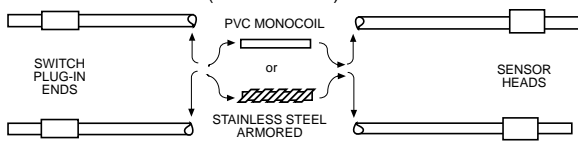

(Order Quantity of Two)

BIFURCATED CABLE (for Diffuse Sensing)

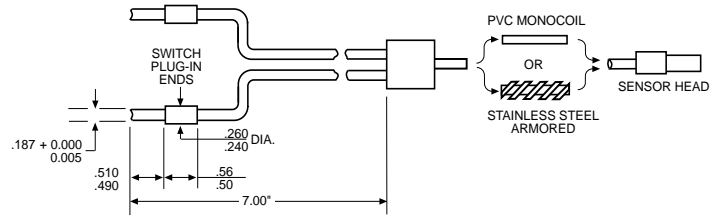

(Order Quantity of One)

Common Cable Applications

PLAIN TIP

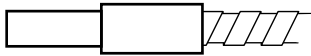

For general purpose use: may be fixed in-place with set screw; most common tip; furthest "Prox" thru-beam range.

PLAIN TIP 90°

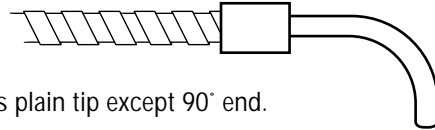

Same as plain tip except 90° end.

THREADED TIP

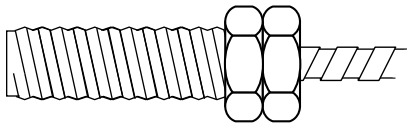

Same as Plain Tip but with brass threaded end; two jam nuts are furnished.

TIGHT TIP 90°



Tight 90° for use in close quarters; may be mounted on chute from vibrator feeder to monitor parts in automatic assembly operations.

HYPO TIP

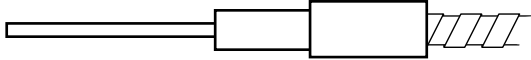

For very small parts or inaccessible areas: diffuse cable could "see" the edge of this page.

FLARE TIP WIDE

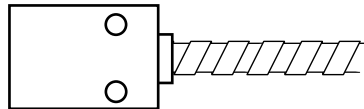

Used for edge control – detects very thin edges. With diffuse sensing, very small parts are detected when passed any place in front of the bundle height. Diffuse type also used for register marks detection.

HYPO TIP BENDABLE

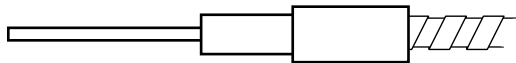

Same as standard hypo tip but tip may be bent to suit; min. bend 1/4"R. and not closer than 1/2" from either end.

FLARE TIP NARROW



Same as flare tip wide except smaller bundle height.

HYPO TIP 90°

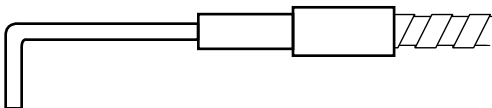

Same as standard hypo tip but with 90° bend. May be mounted very close along side narrow conveyor while viewing across it.



2013 West Meeting Street • Lancaster, SC 29720
1-803-286-8491 • FAX: 1-800-678-6263
www.namcocontrols.com

For technical assistance, call 1-800-NAMTECH

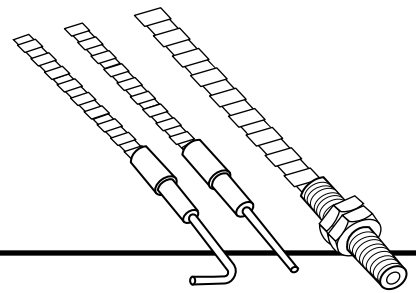

Dimensional Drawings

PLAIN TIP

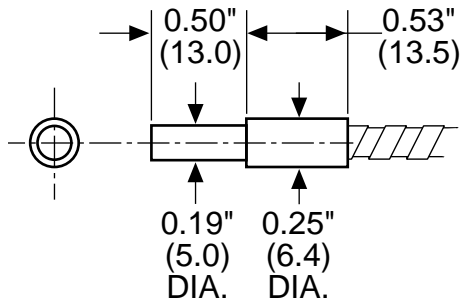

THREADED TIP

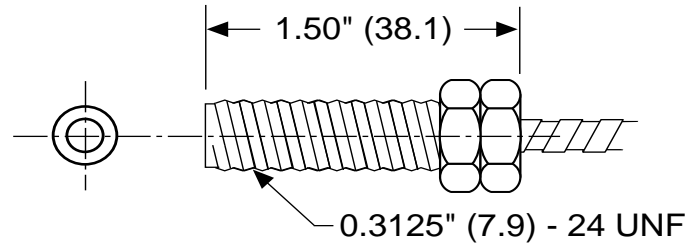

PLAIN TIP 90°

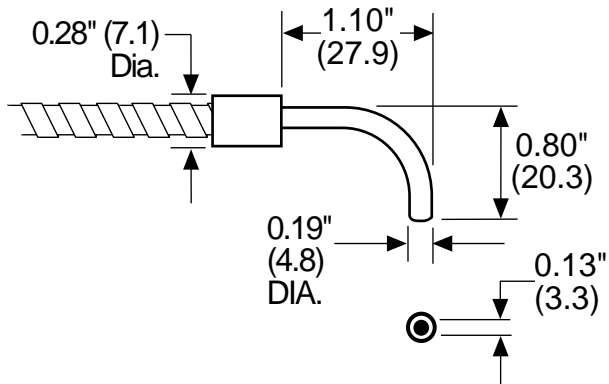

TIGHT TIP 90°

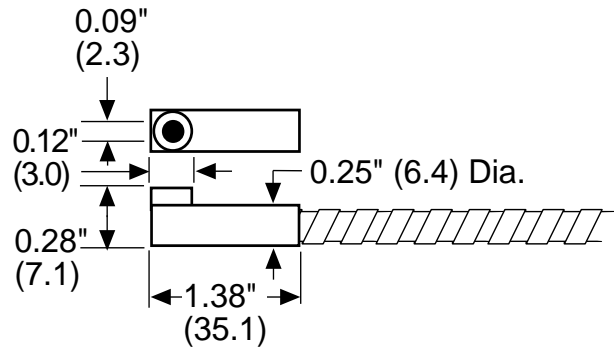

Dimensional Drawings

FLARE TIP WIDE

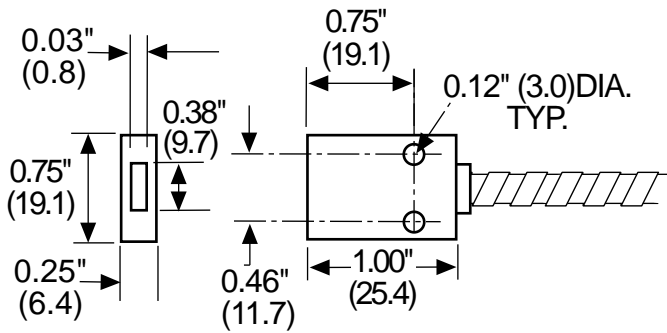

FLARE TIP NARROW

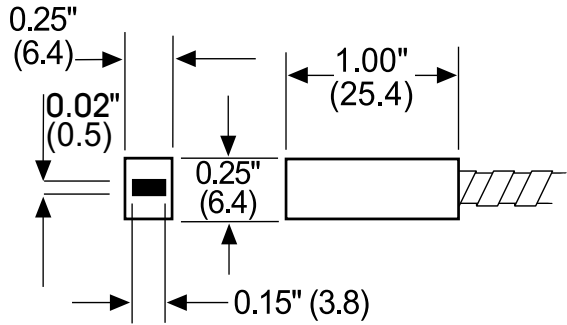

HYPOTIP

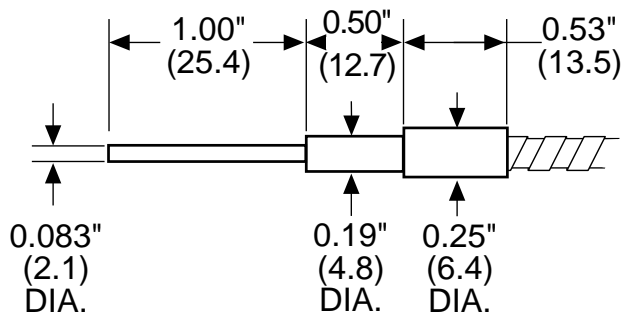

HYPOTIP 90°

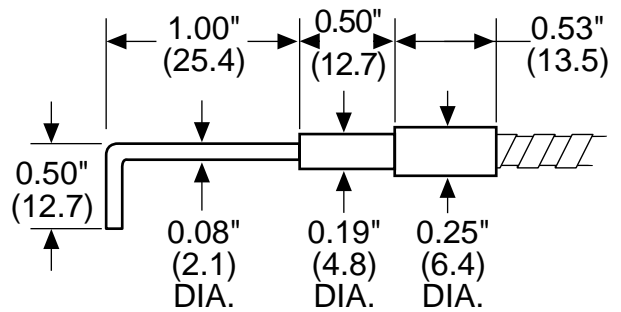

HYPOTIP BENDABLE

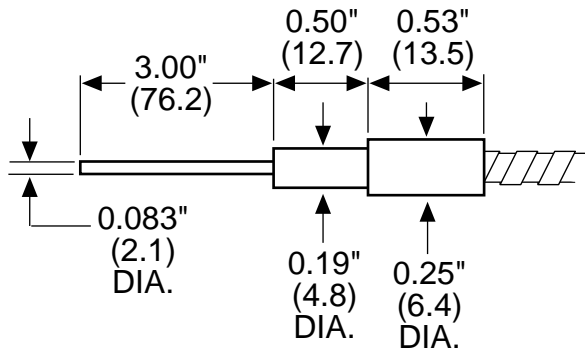

NAMCO

2013 West Meeting Street • Lancaster, SC 29720
 1-803-286-8491 • FAX: 1-800-678-6263
www.namcocontrols.com

For technical assistance, call 1-800-NAMTECH

BRACKETS FOR EP200 SERIES

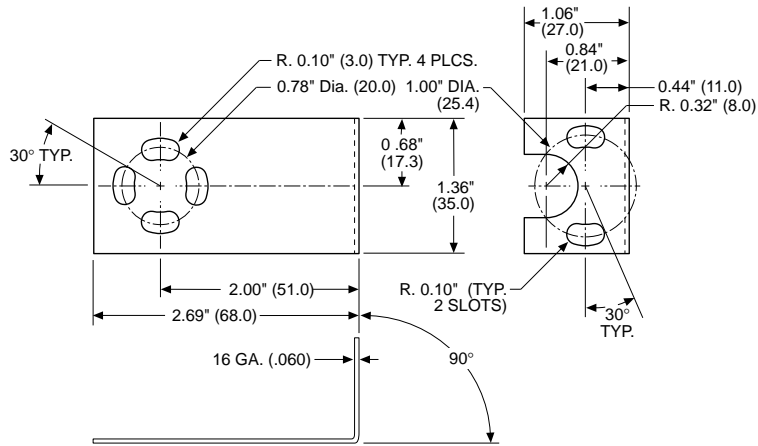

Part No. EP180-20010
Material: Cadmium Plated Steel

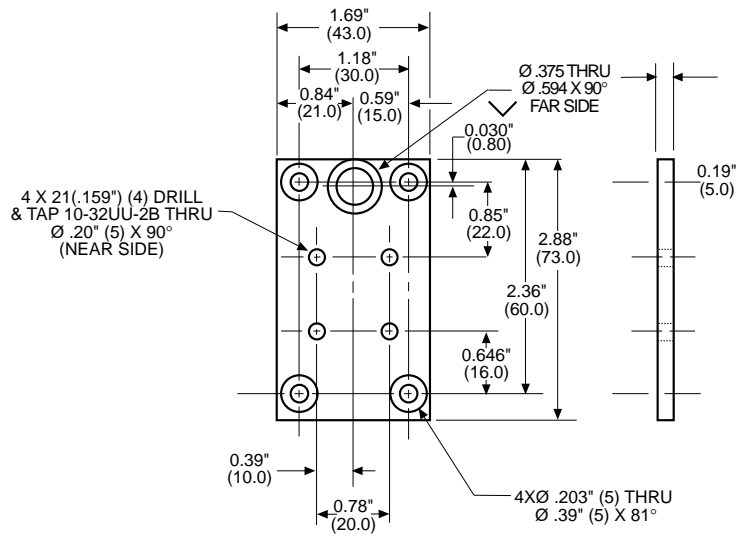

Part No. EP180-20011
Material: Aluminum Clear Anodized

BRACKET FOR TRI-COLOR UNITS

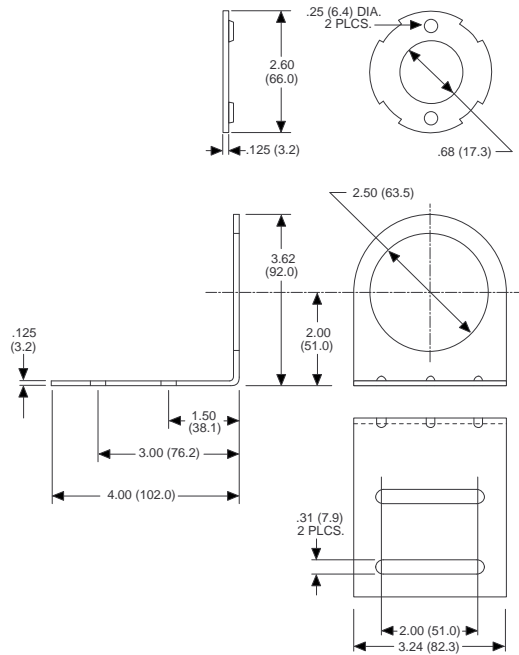

Part No. EP180-40000 (Swivel)
Material: Cadmium Plated Steel

BRACKET FOR EP570 SERIES

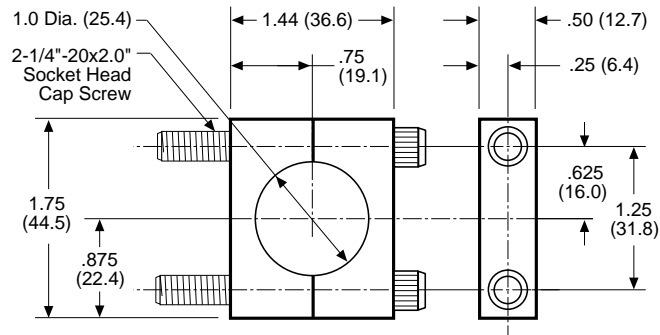

Part No. EP180-50000
(Used with EP570)
Material: Cadmium Plated Steel



2013 West Meeting Street • Lancaster, SC 29720
1-803-286-8491 • FAX: 1-800-678-6263
www.namcocontrols.com

For technical assistance, call 1-800-NAMTECH

Reflectors

Photoelectric Sensor Accessories

The reflector is 50% of a retro-reflective system. Namco tests each reflector to insure its performance. Constructed from a sealed plexiglass assembly, they will operate in most environments. For harsh environments such as solvents or strong chemicals use glass reflectors on next page.

To reduce the effective area of a reflector, mask it with tape or metal shields - NEVER CUT A REFLECTOR. (Exception : EP175-31200 tape)

All Namco Retro-Reflective Units are rated with EP175-13900 (4" x 4") reflector. See chart for additional range information.

Namco High Temperature Reflectors are the same high quality as general purpose types but are designed to withstand environments beyond the norm such as applications requiring "wash down" or in areas where solvents such as toluene or trichloroethylene are present. Temperatures of up to 120°C present no problem.

Namco also offers a metal reflector that will withstand a constant temperature of 480°C (900°F).

Recommended Ranges for Various Reflectors*

Reflector Model No.	SERIES	
	EP110	EP210
EP175-13900	0-30.0 ft.	0-10.0 ft.
EP175-31900	0-27.0 ft.	0-8.5 ft.
EP175-21000	1.5-9.0 ft.	0.3-3.0 ft.
EP175-23200	1.5-22.5 ft.	0.3-8.0 ft.
EP175-22400	0-20.0 ft.	0.3-6.0 ft.
EP175-31200	0.75-15.0 ft.	0.3-4.0 ft.
EP175-37100	0-20.0 ft.	0-7.0 ft.
EP175-32000	0-15.0 ft.	0-6.0 ft.
EP175-22600	0-15.0 ft.	0-6.0 ft.
EP175-23201	1.5-22.5 ft.	0.3-8.0 ft.
EP175-14000	0-12.0 ft.	0-4.0 ft.

* Rated with clean environment, lens & reflector.

GENERAL PURPOSE REFLECTOR (Adhesive or Bracket mount)

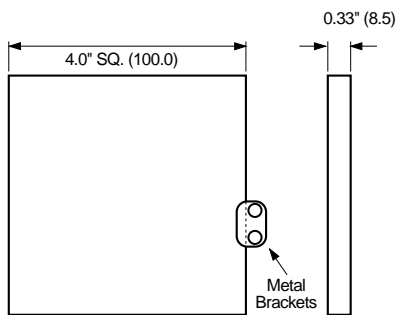

Reflector EP175-13900
(Supplied with 2 metal brackets)

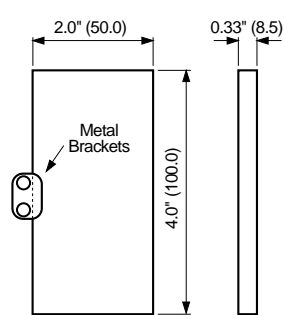

Reflector EP175-31900
(Supplied with 2 metal brackets)

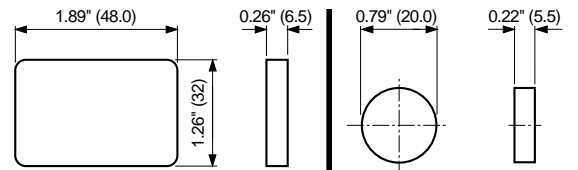

Reflector EP175-32000

Reflector EP175-21000

Material: Plastic PMMA 8N (Plexiglass)
Temperature Range: -20°C to +60°C
Mounting: with glue, double face tape, or with brackets

**GENERAL PURPOSE REFLECTOR
(with Mounting Holes)**

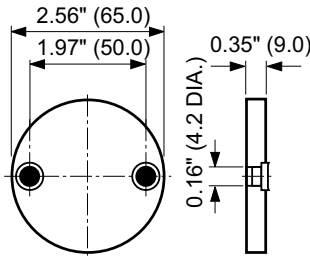

Reflector EP175-22600
Mounting holes for #6 screws

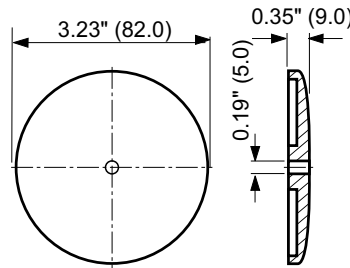

Reflector EP175-23200
Mounting hole for #8 screws

Material: Plastic PMMA 8N (Plexiglass)
Temperature Range: -20°C to +60°C
Mounting: with glue or screws

HEATED REFLECTOR

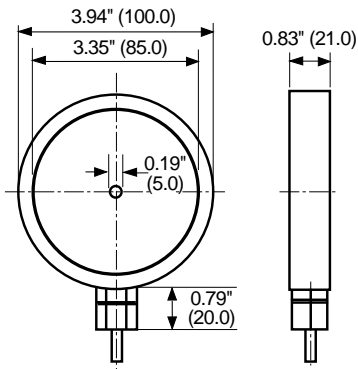

EP175-23201
Heated Reflector

Material: Plastic PMMA 8N (Plexiglass)
Temperature Range: -20°C to +60°C
Cable Length: 2M (6.6 ft.)
Input: 110VAC/2.0VA
Designed to operate in high humidity, fog, freezers, or outdoors and will keep reflective surface clear allowing proper performance. Shipped with EP175-23200 reflector. (Other voltages available.)

REFLECTIVE TAPE

EP175-31200

- Adhesive backed reflective tape
- 1" x 12" mylar coated, honey combed sealed

Application Note: When cutting to size, allow for loss of reflective surface at cut edge.

HIGH TEMPERATURE GLASS

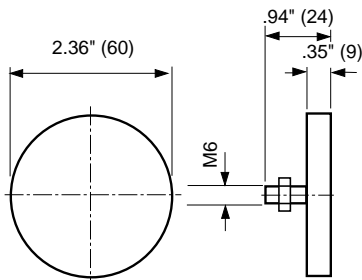

Reflector EP175-22400

Material: Glass
Temperature Range: -20°C to +120°C
Mounting: stud with nut

HIGH TEMPERATURE METAL

Namco High Temperature Reflectors are the same high quality as general purpose types but are designed to withstand environments beyond the norm. Applications requiring "wash down" or in areas where solvents such as toluene or trichloroethylene are present. Temperatures of 120°C present no problem. Totally encased, glass corner-cube elements allow this type of performance.

Namco now offers a metal reflector that will withstand a constant temperature of 480°C (900°F).

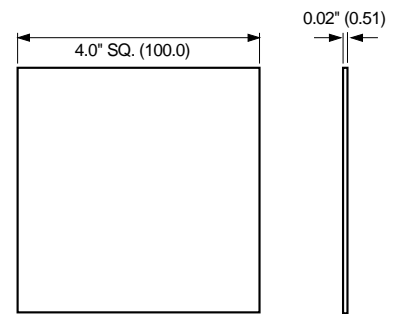

Reflector EP175-14000

Material: Aluminum .020 thk. (51mm)
Temperature Range: -20°C to +480°C (900°F)
Intermittent to +540°C (1000°F)
Mounting: May be cut to size and attached with screws or clamps. May be cleaned with detergent and rinsed with water.



2013 West Meeting Street • Lancaster, SC 29720
1-803-286-8491 • FAX: 1-800-678-6263
www.namcocontrols.com

For technical assistance, call 1-800-NAMTECH

Plug-In Time Delays

Photoelectric Sensor Accessories

Photoelectric Sensors

Model No.	Delay	ON Delay*	OFF Delay**	Description
EP115-00020	Adjustable ON & OFF; Retriggerable	250 ms to 10 sec.	250 ms to 10 sec.	Shifts Output signal.
EP115-00040	Adjustable ON	250 ms to 10 sec.	None	Output and Input turn OFF at the same point (signal removal).
EP115-00060	Adjustable OFF	None	250 ms to 10 sec.	Output turns ON with Input (catches and stretches short input signals).
EP115-00080	Adjustable ON; Adjustable One Shot (Single Pulse)	100 ms to 5 sec.	Output pulse duration: 100 ms to 5 sec.	Provides uniform Output signal for different Input signals (pulse starts at the end of ON delay period).

* Input signal must be longer than ON delay setting. Shorter input signals will be ignored.

** Input signal must be OFF longer than OFF delay setting.

⚠ When ordering factory installed time-delay units, specify model number to be installed with required time delay.

⚠ Consult factory for plug-in "Under Speed" logic boards. Switch output is held unless speed drops below present pulse rate.

Plug-In Time Delays/Installation

PLUG-IN TIME DELAY FEATURES

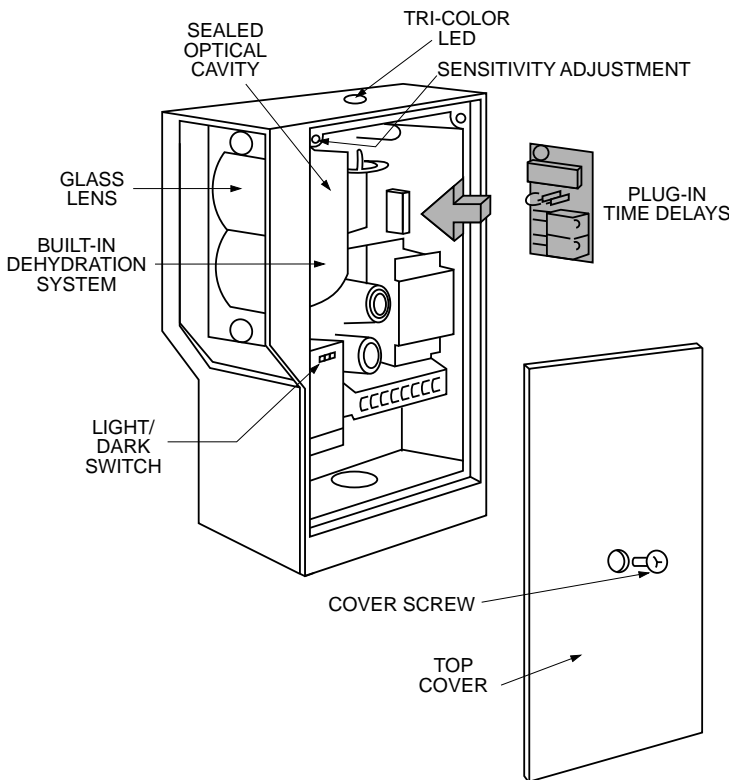

EP115-00020 – DUAL "ON" & "OFF" DELAY

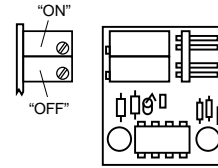

EP115-00040 – "ON" DELAY

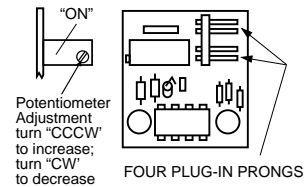

EP115-00060 – "OFF" DELAY

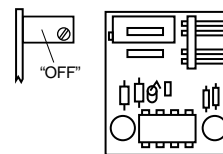

EP115-00080 – DELAYED ONE SHOT

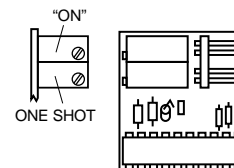

Plug-In Time Delay Graphics

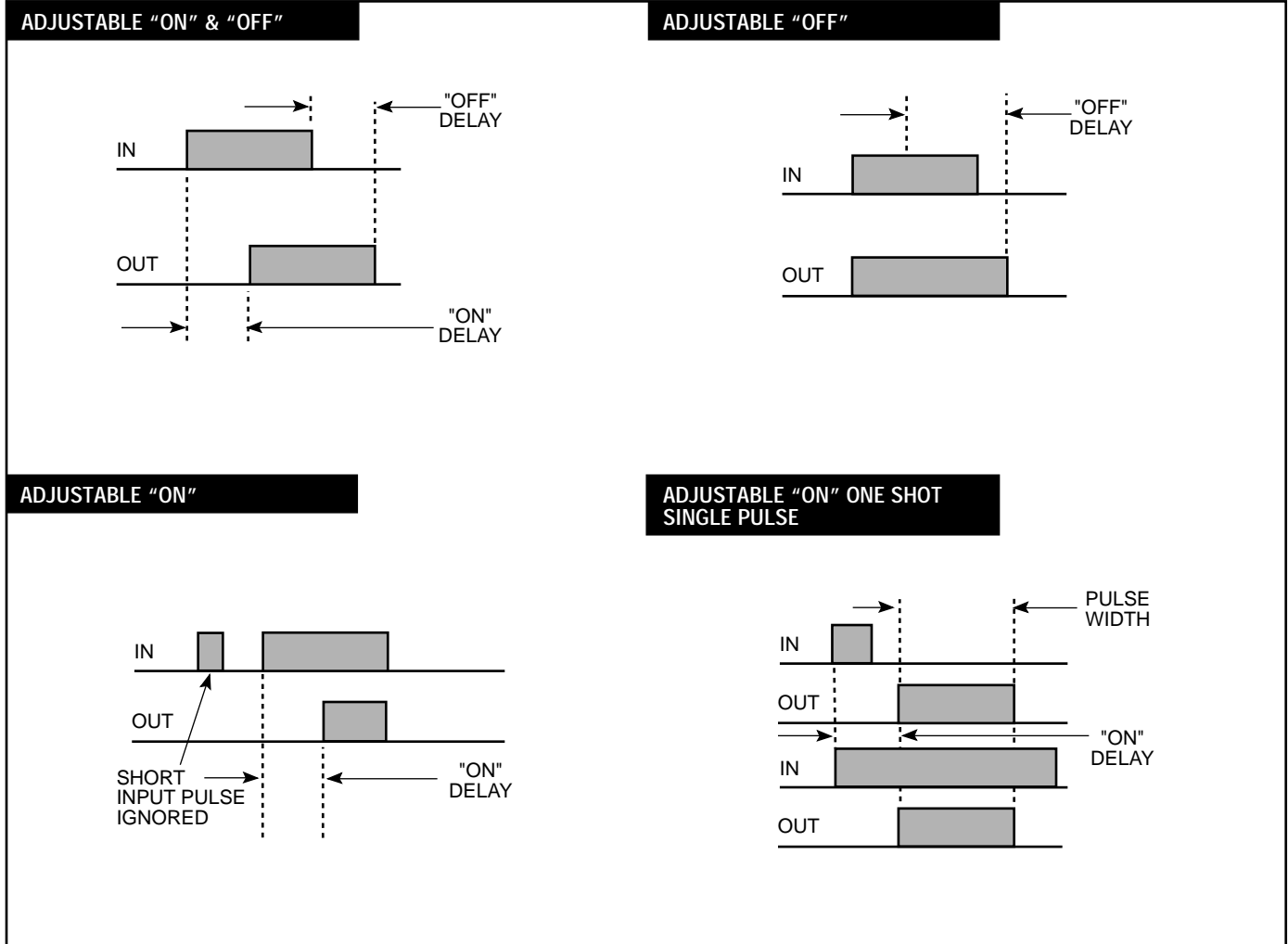

Specifications

PLUG-IN TIME DELAYS	
Retriggerable	Timing function will re-start if another object is sensed prior to completion of initial delay setting.
Non-Retriggerable	Timing function will not re-start until full cycle is completed.

NAMCO

2013 West Meeting Street • Lancaster, SC 29720
 1-803-286-8491 • FAX: 1-800-678-6263
www.namcocontrols.com

For technical assistance, call 1-800-NAMTECH